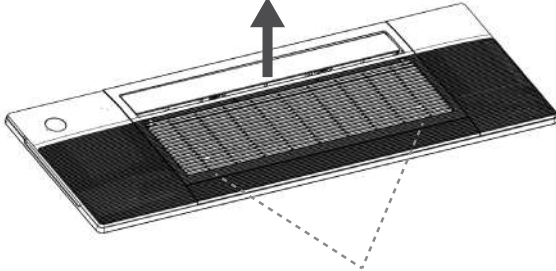
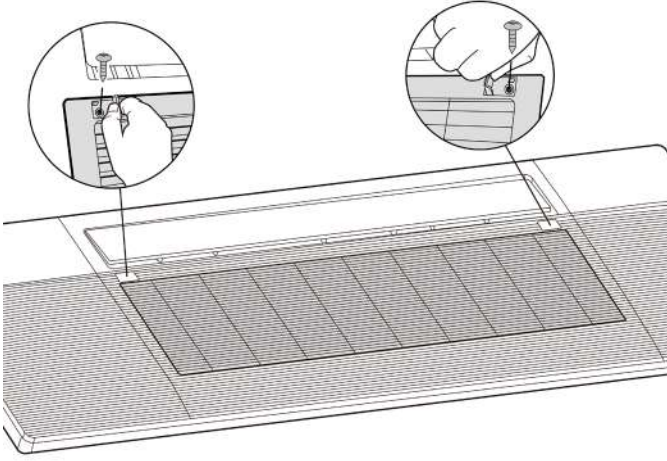

Indoor Unit Disassembly-One-way Cassette

Contents

1.	Indoor Unit Disassembly.....	1
1.1	Filter and Panel.....	2
1.2	Display Board.....	6
1.3	Electrical Parts.....	7
1.4	Water Collector & Water Level Switch.....	10
1.5	Water Pump.....	11
1.6	Evaporator.....	12
1.7	Fan Motor and Fan.....	14
1.8	Stepper Motor.....	15

1. Indoor Unit Disassembly

1.1 Filter and Panel

Procedure	Illustration
<p>1) For panel with lift function, grab air grille with your fingers and pull it out slowly in the direction of the arrow (see Fig. 1).</p> <p>2) For panel without lift function, push one side of the grille clamp (on the both sides of the grille), and then remove 2 screws (see Fig. 2).</p>	 <p data-bbox="965 817 1252 851">Grab at these locations</p> <p data-bbox="933 896 1029 929">Figure 1</p>  <p data-bbox="933 1523 1029 1556">Figure 2</p>

Note: This section is for reference only. Actual unit appearance may vary.

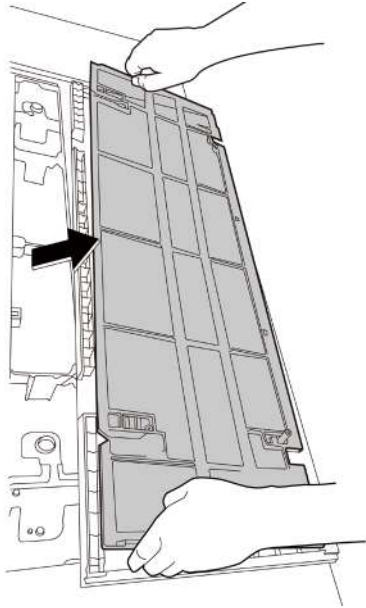
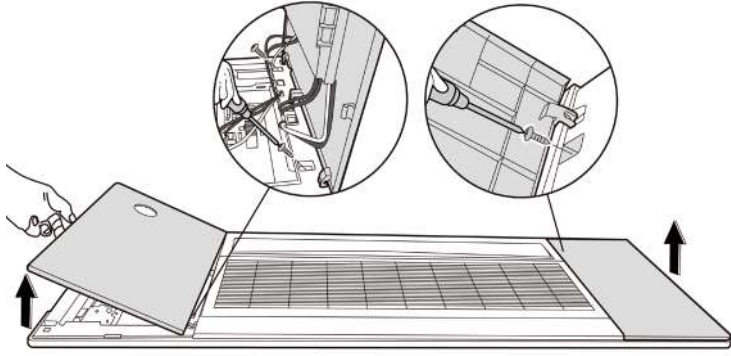
Procedure	Illustration
<p>3) Turn over the air inlet grille assembly then take out the filter (see Fig. 3).</p>	 <p style="text-align: center;">Figure 3</p>
<p>4) Open the two covers on both sides of the panel and remove the 3 screws (see Fig. 4).</p>	 <p style="text-align: center;">Figure 4</p>

Note: This section is for reference only. Actual unit appearance may vary.

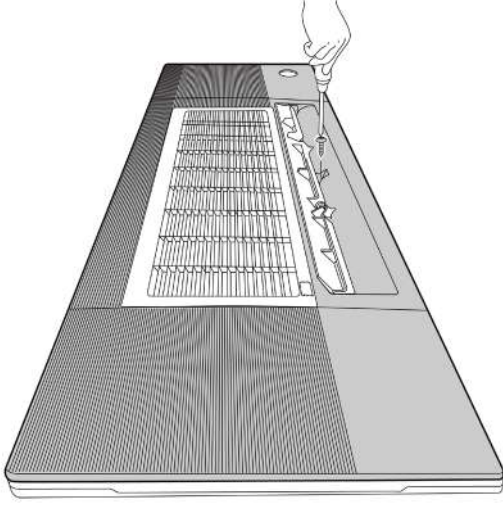
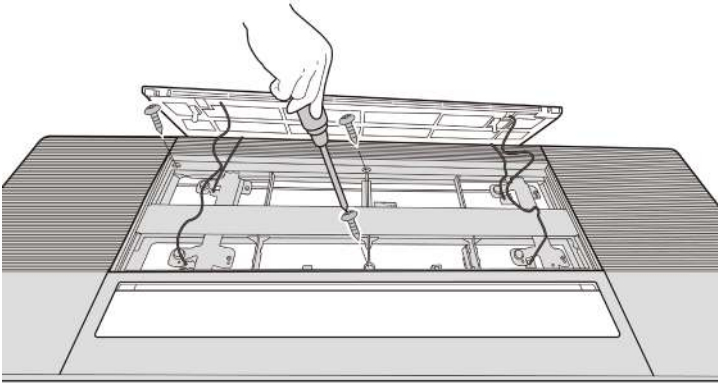
Procedure	Illustration
<p>5) Open the louver and open the screw cover, then remove the screw (see Fig. 5).</p> <p>6) Remove 3 screws (see Fig. 6).</p>	 <p data-bbox="935 913 1034 945">Figure 5</p>  <p data-bbox="935 1473 1034 1505">Figure 6</p>

Note: This section is for reference only. Actual unit appearance may vary.

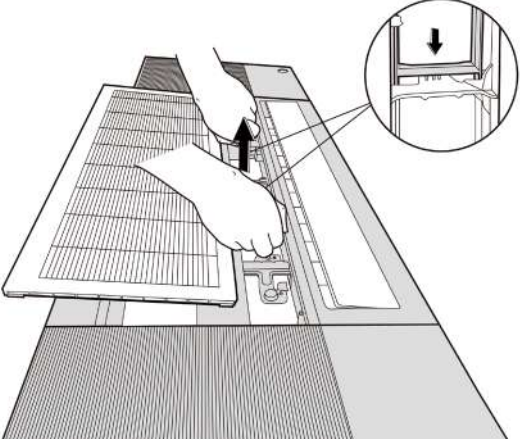
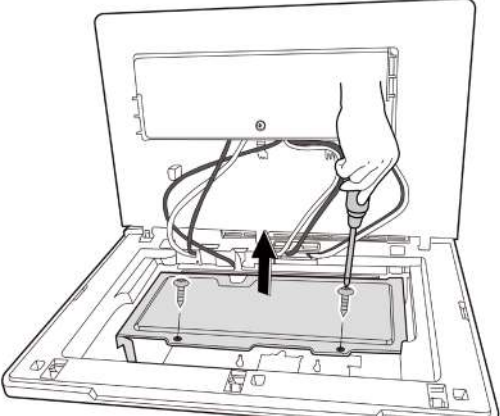
Procedure	Illustration
<p>7) Separate panel and water collector, then remove the panel (see Fig. 7).</p>	 <p style="text-align: center;">Figure 7</p>
<p>8) Remove 2 screws and remove the cover of electronic control box (see Fig. 8).</p> <p>9) Disconnect the connectors of display board and stepper motor and release the panel.</p>	 <p style="text-align: center;">Figure 8</p>

Note: This section is for reference only. Actual unit appearance may vary.

1.2 Display Board

Note: Open the left cover of panel (refer to 1.1. filter and panel) before disassembling display board.

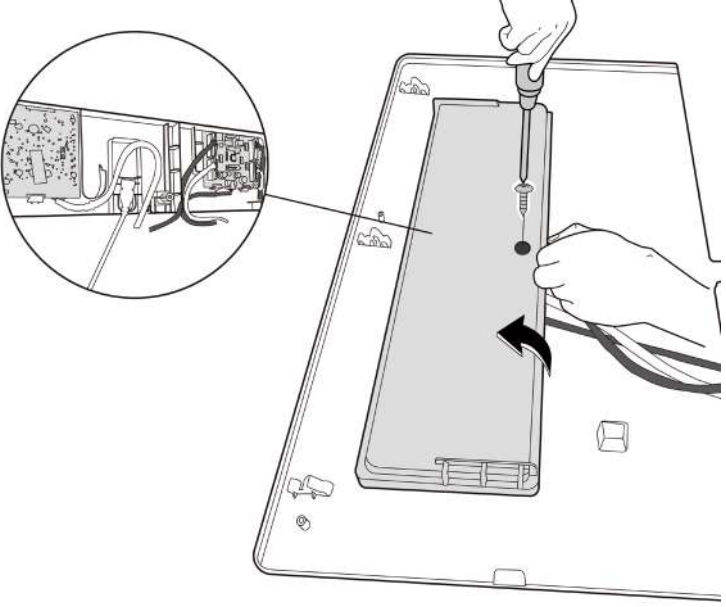
Procedure	Illustration
<p>1) Remove 1 screw of display board subassembly (see Fig. 9).</p>	 <p data-bbox="933 1153 1029 1187">Figure 9</p>

Note: This section is for reference only. Actual unit appearance may vary.

1.3 Electrical Parts (Antistatic gloves must be worn.)

Note: Remove the panel (refer to 1.1) before disassembling electronic control box subassembly.

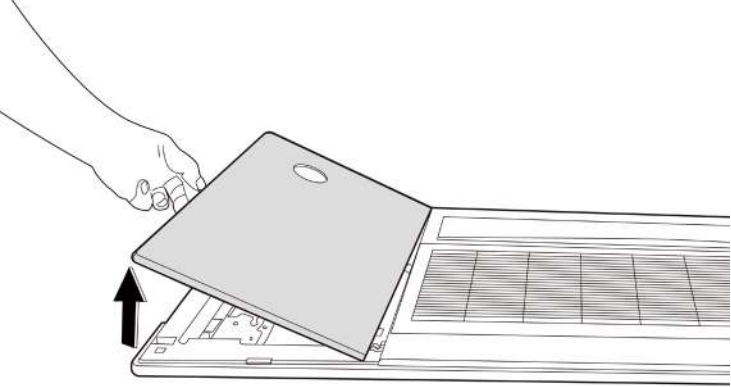
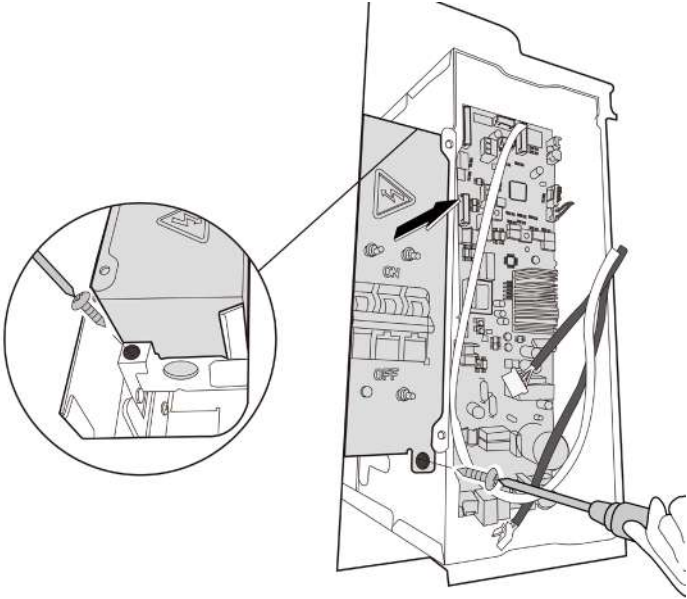
Procedure	Illustration
<p>1) Open left cover of panel (see Fig. 10).</p> <p>2) Remove 2 screws and remove the cover of electronic control box (see Fig. 8).</p>	 <p data-bbox="932 913 1040 945">Figure 10</p>
<p>3) Remove 2 screws of air switch cover (see Fig. 11)(for some models).</p>	 <p data-bbox="932 1693 1040 1724">Figure 11</p>

Note: This section is for reference only. Actual unit appearance may vary.

Procedure	Illustration
<p>4) Disconnect connectors and then remove the main control board (3 clips) (see Fig. 12).</p> <p>(If wanting to repair the main control board assembly, perform steps 1 to 4; If wanting to repair the electrical control box subassembly, perform steps 5 to 6 as follows.)</p>	

Figure 12

Note: This section is for reference only. Actual unit appearance may vary.

Procedure	Illustration
<p>5) Remove 4 screws of electronic control box subassembly (see Fig. 13-1 & Fig. 13-2).</p> <p>6) Remove the electronic control box subassembly.</p> <p>Note: Remove the panel (refer to 1.1) before disassembling electronic control box subassembly.</p>	 <p data-bbox="919 1153 1050 1182">Figure 13-1</p>  <p data-bbox="919 1787 1050 1816">Figure 13-2</p>

Note: This section is for reference only. Actual unit appearance may vary.

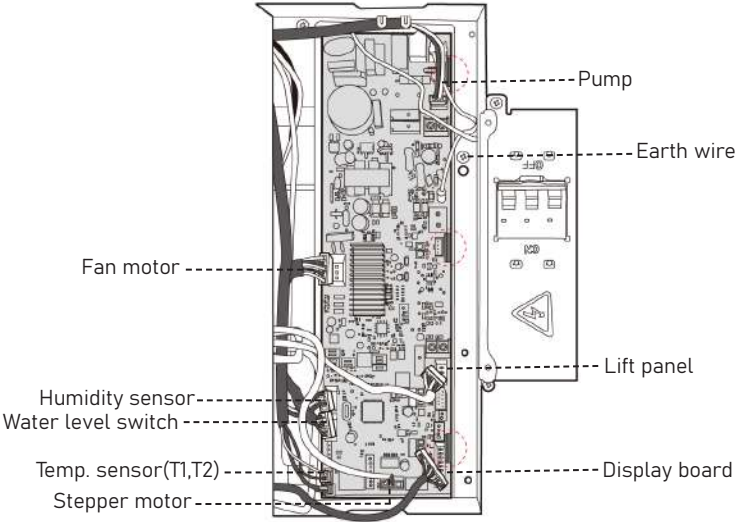
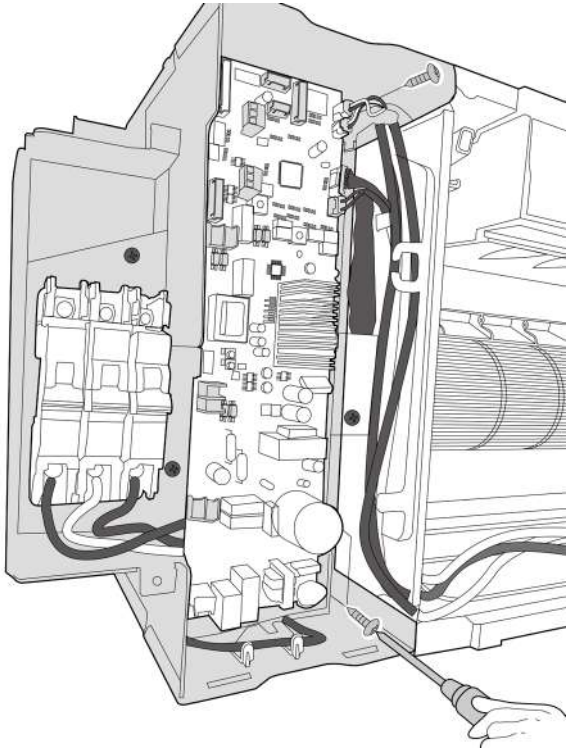
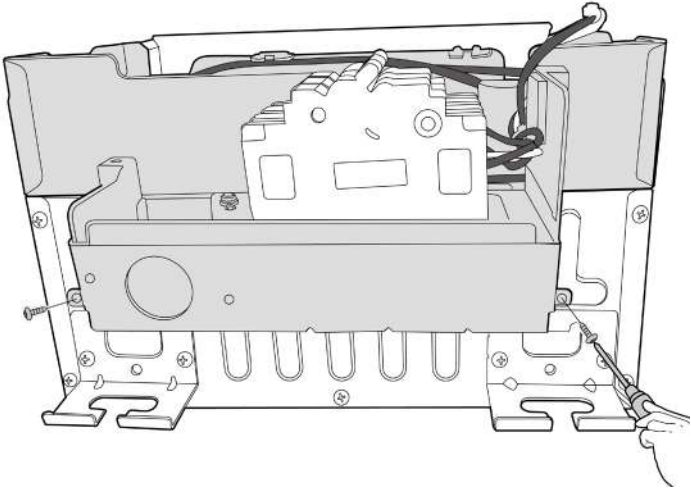
1.4 Water Collector

Note: Remove the panel (refer to 1.1) before disassembling water collector.

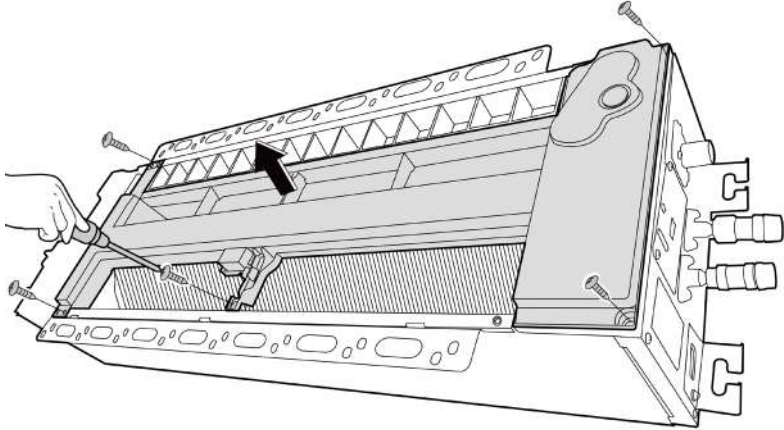
Procedure	Illustration
<p>1) Remove the 5 screws and remove the water collector (see Fig. 14).</p>	 <p data-bbox="932 1014 1038 1043">Figure 14</p>

Note: This section is for reference only. Actual unit appearance may vary.

1.5 Water Pump

Note: Remove the panel & water collector (refer to 1.1 & 1.4) before disassembling water pump.

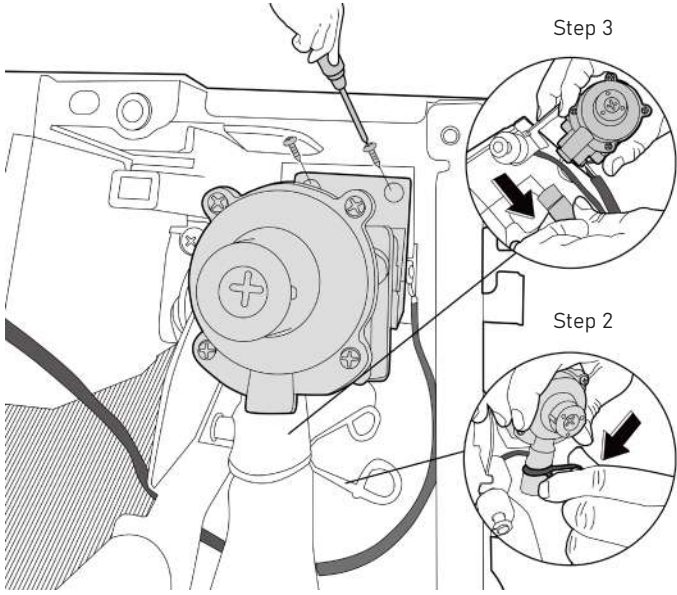
Procedure	Illustration
<ol style="list-style-type: none">1) Remove 2 screws and take out water pump assembly (see Fig. 15).2) Loosen the spring (see Fig. 15).3) Pull out the drain pipe (see Fig. 15).	 <p>Figure 15</p>

Note: This section is for reference only. Actual unit appearance may vary.

1.6 Evaporator

Note: Remove the panel, water collector & water pump (refer to 1.1, 1.4, & 1.5) before disassembling evaporator.

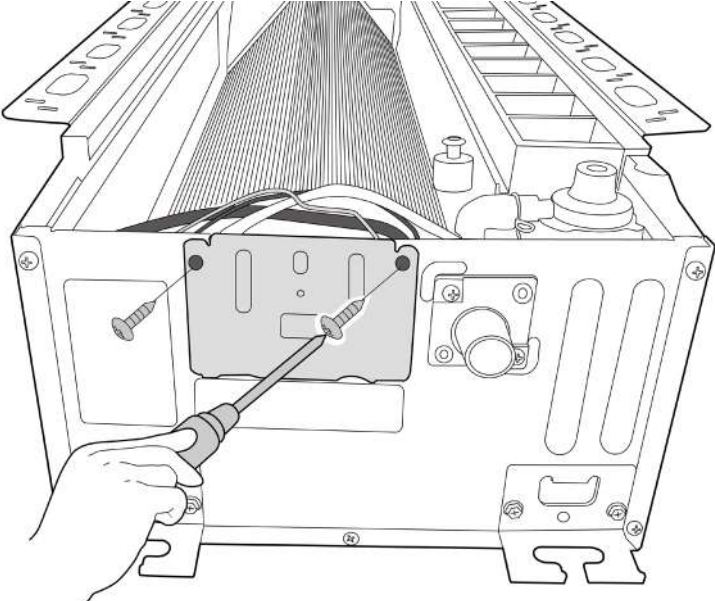
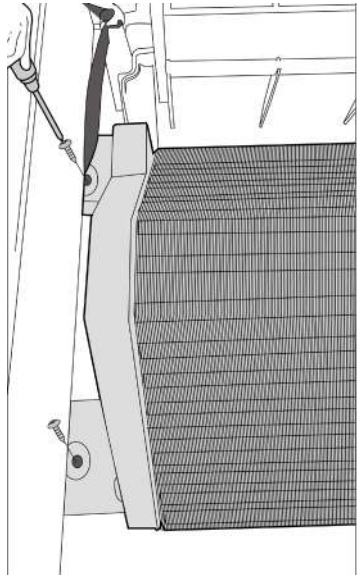
Procedure	Illustration
<p>1) Remove the 2 screws of the pipe clamp board (see Fig. 16).</p> <p>2) Remove 2 screws on the left of the evaporator fixing bracket (see Fig. 17).</p>	 <p style="text-align: center;">Figure 16</p>  <p style="text-align: center;">Figure 17</p>

Note: This section is for reference only. Actual unit appearance may vary.

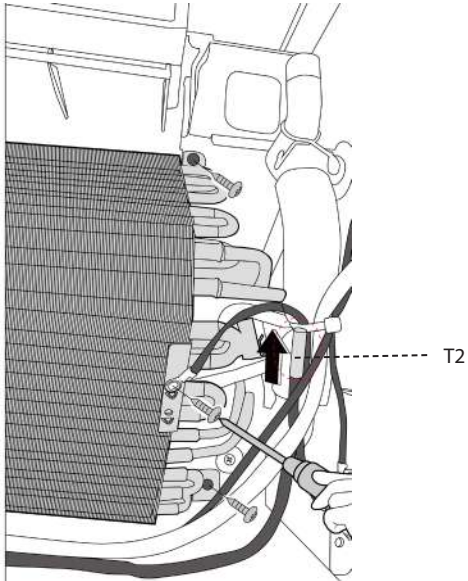
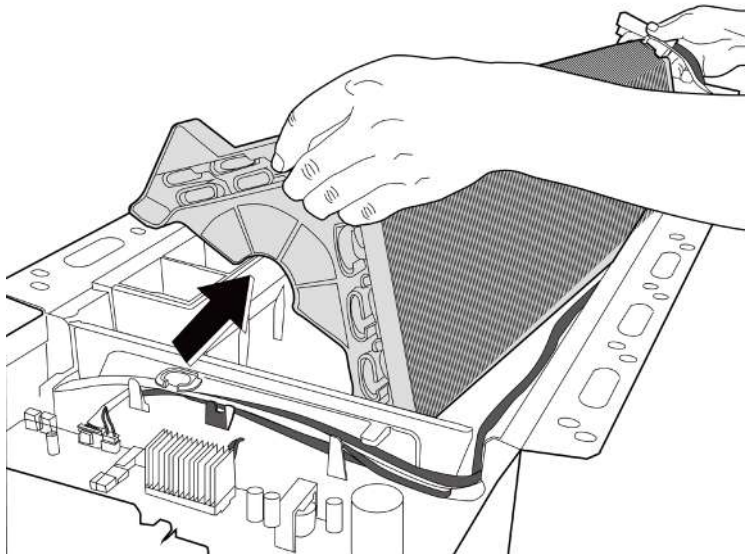
Procedure	Illustration
<p>3) Remove 2 screws on the right of the evaporator.</p> <p>4) Cut the ribbon by use of a cutting tool, then pull out the coil temp. sensor (T2) and remove 1 ground screw (see Fig. 18).</p>	 <p style="text-align: center;">Figure 18</p>
<p>5) Remove the evaporator (see Fig. 19).</p>	 <p style="text-align: center;">Figure 19</p>

Note: This section is for reference only. Actual unit appearance may vary.

1.7 Fan Motor and Fan

Note: Remove the panel, electrical parts, water collector, water pump, evaporator (refer to 1.1, 1.3, 1.4, 1.5 & 1.6) before disassembling the fan motor.

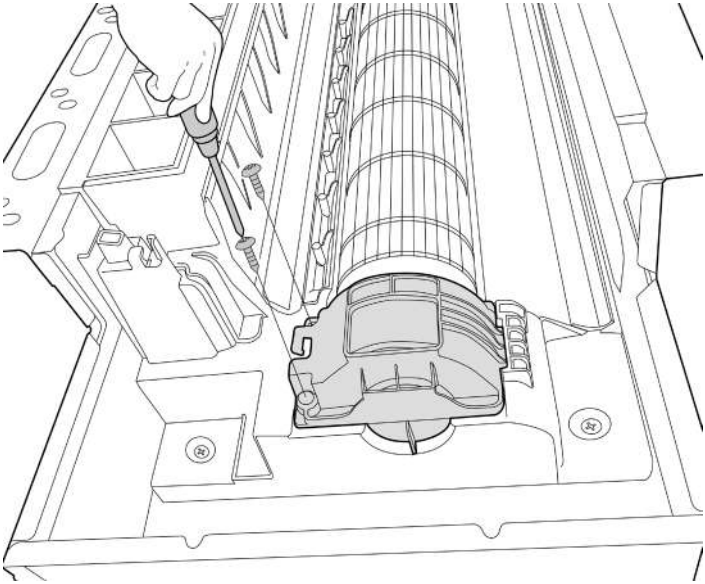
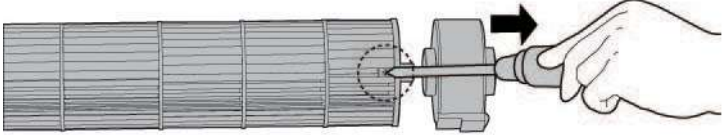
Procedure	Illustration
<p>1) Remove 2 screws of fan motor base (see Fig. 20).</p>	 <p data-bbox="932 1122 1043 1151">Figure 20</p>
<p>2) Pull out the fan motor and fan assembly.</p> <p>3) Remove the fastening screw and remove the fan motor (see Fig. 21).</p>	 <p data-bbox="932 1429 1043 1458">Figure 21</p>

Note: This section is for reference only. Actual unit appearance may vary.

1.8 Stepper Motor

Note: Remove the panel (refer to 1.1) before disassembling stepper motor.

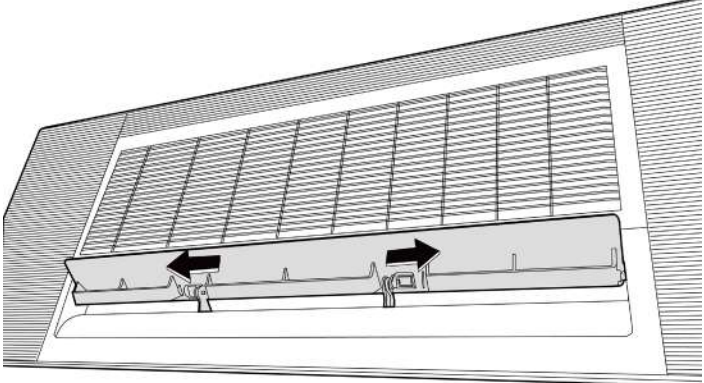
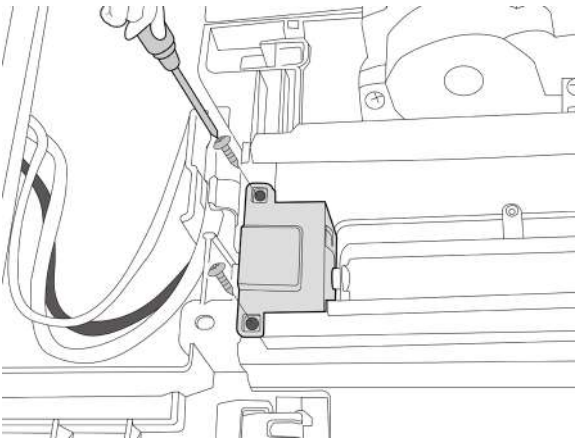
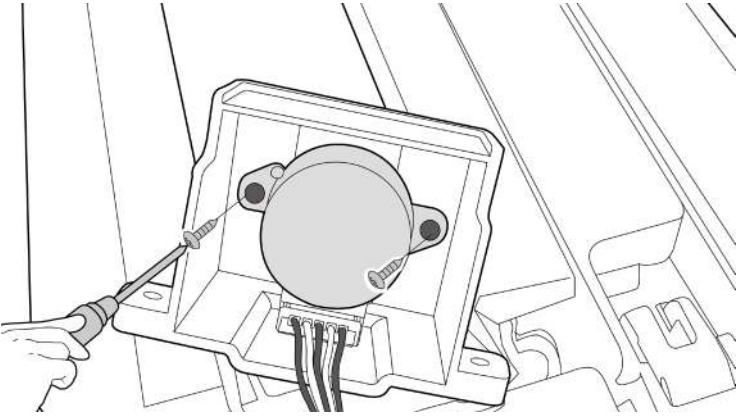
Procedure	Illustration
<p>1) Open the louver and push the hooks in the direction shown in the right side picture (see Fig. 22).</p>	
<p>2) Remove 2 screws fixing the motor cover, and remove it (see Fig. 23).</p>	<p data-bbox="933 869 1045 902">Figure 22</p> 
<p>3) Remove 2 screws and remove the stepper motor (see Fig. 24).</p>	<p data-bbox="933 1377 1045 1411">Figure 23</p> 

Note: This section is for reference only. Actual unit appearance may vary.