

WYQ SINGLE SPLIT 3D DC INVERTER AIR CONDITIONER - HEAT PUMP SERVICE MANUAL *Single Zone 3D*

Revision A: 1403180001, Content updated.

PIONEER Model Numbers:

WYQ009GMFI22RL (Indoor: WQ009GMFI22HLD Outdoor: YN009GMFI22RPD) - 23.5 SEER
WYQ012GMFI22RL (Indoor: WQ012GMFI22HLD Outdoor: YN012GMFI22RPD) - 22.0 SEER
WYQ018GMFI22RL (Indoor: WQ018GMFI22HLD Outdoor: YN018GMFI22RPD) - 21.0 SEER
WYQ024GMFI22RL (Indoor: WQ024GMFI22HLD Outdoor: YN024GMFI22RPD) - 19.0 SEER

Table of Contents

1. Precaution
2. Part Names And Functions
3. Dimension
4. Refrigerant Cycle Diagram
5. Wiring Diagram
6. Installation Details
7. Operation Characteristics
8. Electronic Function
9. Troubleshooting
10. Disassembly Instructions

PIONEER

ULTRA HIGH EFFICIENCY INVERTER



WARNING

- Installation MUST conform with local building codes or, in the absence of local codes, with the National Electrical Code NFPA70/ANSI C1-1993 or current edition and Canadian Electrical Code Part1 CSA C.22.1.
- The information contained in the manual is intended for use by a qualified service technician familiar with safety procedures and equipped with the proper tools and test instruments
- Installation or repairs made by unqualified persons can result in hazards to you and others.
- Failure to carefully read and follow all instructions in this manual can result in equipment malfunction, property damage, personal injury and/or death.
- **This service is only for service engineer to use.**



CONTENTS

1. Precaution	1
1.1 Safety Precaution	1
1.2 Warning	1
2. Part Names And Functions	4
2.1 Model Names of Indoor/Outdoor units	4
2.2 Part names of Indoor/Outdoor units	4
2.3 Functions of Indoor/Outdoor units	5
3. Dimension	7
3.1 Indoor Unit	7
3.2 Outdoor Unit	9
4. Refrigerant Cycle Diagram	10
5. Wiring Diagram	11
5.1 Indoor Unit	11
5.2 Outdoor Unit	12
6 Installation Details	16
6.1 Wrench torque sheet for installation	16
6.2 Connecting the cables	16
6.3 Pipe length and the elevation	16
6.4 Installation for the first time	16
6.5 Adding the refrigerant after running the system for many years	18
6.6 Re-installation while the indoor unit need to be repaired	18
6.7 Re-installation while the outdoor unit need to be repaired	19
7. Operation Characteristics	21
8. Electronic Function	22
8.1 Abbreviation	22
8.2 Display function	22
8.3 Main Protection	23
8.4 Operation Modes and Functions	24
9. Troubleshooting	32
9.1 Indoor Unit Error Display	33
9.2 Outdoor unit error display	34
9.3 Diagnosis and Solution	37
10 Disassembly Instructions	61
10.1 Indoor unit	61
10.2 Outdoor unit	65

1. Precaution

1.1 Safety Precaution

- To prevent injury to the user or other people and property damage, the following instructions must be followed.
- Incorrect operation due to ignoring instruction will cause harm or damage.
- Before service the unit, be sure to read this service manual at first.

1.2 Warning

➤ Installation

- Do not use a defective or underrated circuit breaker. Use this appliance on a dedicated circuit.

There is risk of fire or electric shock.

- For electrical work, contact the dealer, seller, a qualified electrician, or an authorized service center.

Do not disassemble or repair the product, there is risk of fire or electric shock.

- Always ground the product.

There is risk of fire or electric shock.

- Install the panel and the cover of control box securely.

There is risk of fire of electric shock.

- Always install a dedicated circuit and breaker.

Improper wiring or installation may cause electric shock.

- Use the correctly rated breaker of fuse.

There is risk of fire or electric shock.

- Do not modify or extend the power cable.

There is risk of fire or electric shock.

- Do not install, remove, or reinstall the unit by yourself (customer).

There is risk of fire, electric shock, explosion, or injury.

- Be caution when unpacking and installing the product.

Sharp edges could cause injury, be especially careful of the case edges and the fins on the condenser and evaporator.

- For installation, always contact the dealer or an authorized service center.

- Do not install the product on a defective installation stand.

- Be sure the installation area does not deteriorate with age.

If the base collapses, the air conditioner could fall with it, causing property damage, product failure, and personal injury.

- Do not let the air conditioner run for a long time when the humidity is very high and a door or a window is left open.

- Take care to ensure that power cable could not be pulled out or damaged during operation.

There is risk of fire or electric shock.

- Do not place anything on the power cable.

There is risk of fire or electric shock.

- Do not plug or unplug the power supply plug during operation.

There is risk of fire or electric shock.

- Do not touch (operation) the product with wet hands.

- Do not place a heater or other appliance near the power cable.

There is risk of fire and electric shock.

- Do not allow water to run into electrical parts.

It may cause fire, failure of the product, or electric shock.

- Do not store or use flammable gas or combustible near the product.

There is risk of fire or failure of product.

- Do not use the product in a tightly closed space for a long time.

Oxygen deficiency could occur.

- When flammable gas leaks, turn off the gas and open a window for ventilation before turn the product on.

- If strange sounds or smoke comes from product, turn the breaker off or disconnect the power supply cable.

There is risk of electric shock or fire.

■ **Stop operation and close the window in storm or hurricane. If possible, remove the product from the window before the hurricane arrives.**

There is risk of property damage, failure of product, or electric shock.

■ **Do not open the inlet grill of the product during operation. (Do not touch the electrostatic filter, if the unit is so equipped.)**

There is risk of physical injury, electric shock, or product failure.

■ **When the product is soaked, contact an authorized service center.**

There is risk of fire or electric shock.

■ **Be caution that water could not enter the product.**

There is risk of fire, electric shock, or product damage.

■ **Ventilate the product from time to time when operating it together with a stove etc.**

There is risk of fire or electric shock.

■ **Turn the main power off when cleaning or maintaining the product.**

There is risk of electric shock.

■ **When the product is not be used for a long time, disconnect the power supply plug or turn off the breaker.**

There is risk of product damage or failure, or unintended operation.

■ **Take care to ensure that nobody could step on or fall onto the outdoor unit.**

This could result in personal injury and product damage.

➤ CAUTION

■ **Always check for gas (refrigerant) leakage after installation or repair of product.**

Low refrigerant levels may cause failure of product.

■ **Install the drain hose to ensure that water is drained away properly.**

A bad connection may cause water leakage.

■ **Keep level even when installing the**

product.

It can avoid vibration of water leakage.

■ **Do not install the product where the noise or hot air from the outdoor unit could damage the neighborhoods.**

It may cause a problem for your neighbors.

■ **Use two or more people to lift and transport the product.**

■ **Do not install the product where it will be exposed to sea wind (salt spray) directly.**

It may cause corrosion on the product.

Corrosion, particularly on the condenser and evaporator fins, could cause product malfunction or inefficient operation.

➤ Operational

■ **Do not expose the skin directly to cool air for long time. (Do not sit in the draft).**

■ **Do not use the product for special purposes, such as preserving foods, works of art etc. It is a consumer air conditioner, not a precision refrigerant system.**

There is risk of damage or loss of property.

■ **Do not block the inlet or outlet of air flow.**

■ **Use a soft cloth to clean. Do not use harsh detergents, solvents, etc.**

There is risk of fire, electric shock, or damage to the plastic parts of the product.

■ **Do not touch the metal parts of the product when removing the air filter. They are very sharp.**

■ **Do not step on or put anything on the product. (outdoor units)**

■ **Always insert the filter securely.**

Clean the filter every two weeks or more often if necessary.

A dirty filter reduces the efficiency of the air conditioner and could cause product malfunction or damage.

■ **Do not insert hands or other objects through air inlet or outlet while the product is operated.**

■ **Do not drink the water drained from the product.**

■ **Use a firm stool or ladder when cleaning or maintaining the product.**

Be careful and avoid personal injury.

■ **Replace the all batteries in the remote control with new ones of the same type. Do not mix old and new batteries or different types of batteries.**

There is risk of fire or explosion.

■ **Do not recharge or disassemble the batteries. Do not dispose of batteries in a fire.**

They may burn or explode.

■ **If the liquid from the batteries gets onto your skin or clothes, wash it well with clean water. Do not use the remote if the batteries have leaked.**

2. Part Names And Functions

2.1 Model Names of Indoor/Outdoor units

Series	Capacity	Indoor units	Outdoor units
Inverter	9k	WQ009GMFI22HLD	YN009GMFI22RPD
	12k	WQ012GMFI22HLD	YN012GMFI22RPD
	18k	WQ018GMFI22HLD	YN018GMFI22RPD
	24k	WQ024GMFI22HLD	YN024GMFI22RPD

2.2 Part names of Indoor/Outdoor units

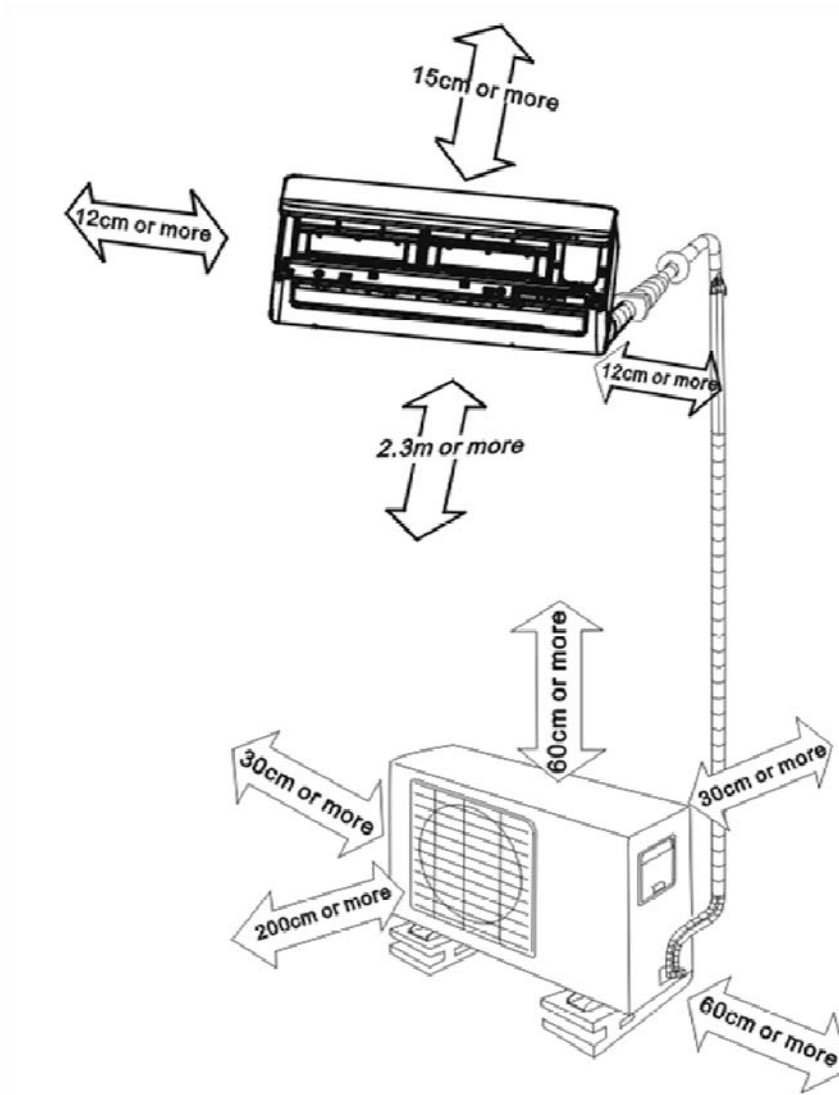

2.3 Functions of Indoor/Outdoor units

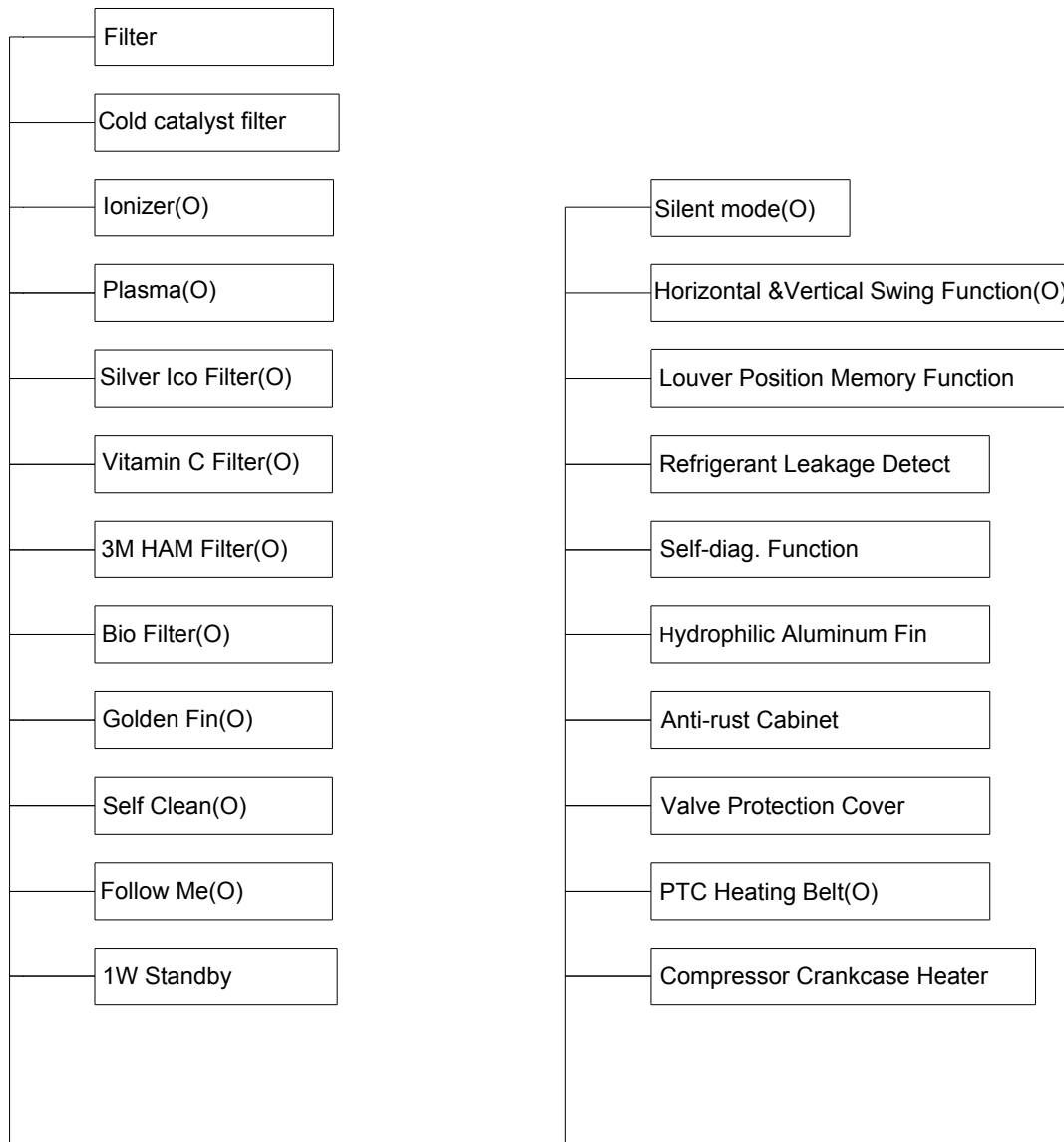

O: optional function

- **Cold Catalyst Filter:**

Eliminate formaldehyde and other volatile organic compounds as well as harmful gases and odors.

- **Ionizer:**

Release negative ions, eliminate odor, dust, smoke and pollen particles to give you fresh and healthy air.

- **Plasma:**

Generate a high voltage electrostatic zone, absorb and eliminate dust, smoke and pollen particles. It also deodorizes air as removing tobacco odours, garbage smells etc.

- **Silver Ion Filter:**

Sterilize bacteria effectively by decomposing cell wall of bacteria.

- **Vitamin C Filter:**

Release Vitamin C which can eliminate active oxygen to beautify the skin.

- **3M HAM Filter:**

Open-hole-structure with charged electrostatic effectively capture dust and particles, ensure maximum air flow and minimum pressure drop.

- **Bio Filter(O):**

Bio filter consists of a specialized biological enzyme and Eco filter. The Eco filter catches very small airborne dust particles and bacteria, fungi and microbes. Biological enzyme kills bacteria by dissolving their cell wall thus eliminating the problem of re-pollution.

- **Golden Fin:**

The Golden hydrophilic condenser can improve the heating efficiency by accelerating the defrosting process. The unique anticorrosive golden coating on the condenser can withstand the salty air, rain and other corrosive elements.

- **Self Clean:**

When this function is activated, firstly the indoor unit operates as Fan-only mode with low fan speed, during this period the condensed water will take some dust on evaporator fins away. After that the unit turns to heating operation with low fan speed which dries the inside of indoor unit. Finally it turns to fan-only mode and blows away the wet air. The whole process cleans the internal side of indoor unit and prevents the breeding of bacteria.

- **Follow me:**

With this technology, a temperature sensor is built in the remote control when you stay close to the remote control, the unit will automatically change the operation mode to supply comfortable temperature just like the air conditioner is following you.

- **Silent mode**

Indoor fan will run at super breeze speed and indoor unit noise level can be extremely low to 20dB(A) when the unit enters silent mode operation.

- **Horizontal&Vertical Swing Function**

The unit has auto horizontal swing and auto vertical swing function, which supplies more even and comfortable air flow.

- **Louver position memory function:**

When starting the unit again after shutting down, its louver will restore to the angle originally set by the user

- **Refrigerant leakage detect:**

The refrigerant leakage detect function can better prevent the compressor being damaged by refrigerant leakage or compressor overload.

- **Self-diag.Function:**

Monitoring some abnormal operations or parts failures, microcomputer of the air conditioner will switch off and protect the system automatically. Meanwhile, the error or protection code will be displayed on the indoor unit.

- **PTC heating belt:**

With a PTC heating belt fitted on the base plate of the outdoor unit, the rain, snow or defrosted water accumulating on the base plate is avoided.

- **Compressor crankcase heater:**

The oil dissolves easily in refrigerant, especially in low temperature condition. The crankcase heating belt can heat the bottom of the compressor to avoid pumping out too much oil with the refrigerant, which helps to protect the compressor.

3. Dimension

3.1 Indoor Unit

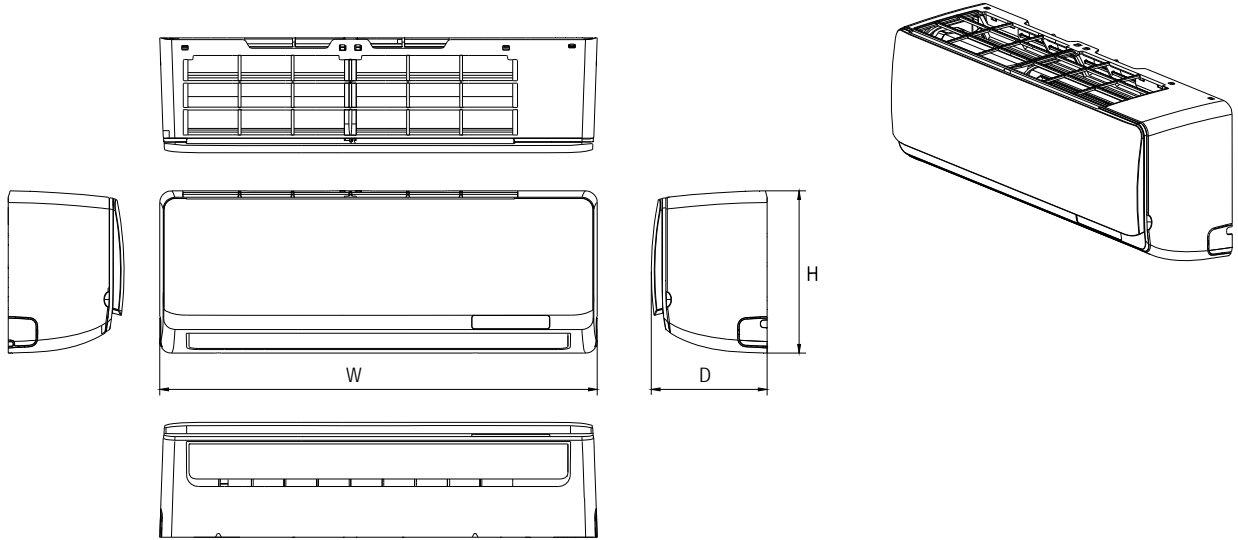

Model	W	D	H
WQ009GMFI22HLD	835mm	198mm	280mm
WQ012GMFI22HLD	(32.9in)	(7.8in)	(11.0in)
WQ018GMFI22HLD	990mm	218mm	315mm
	(39.0in)	(8.6in)	(12.4in)
WQ024GMFI22HLD	1186mm	258mm	340mm
	(46.7in)	(10.2in)	(13.4in)

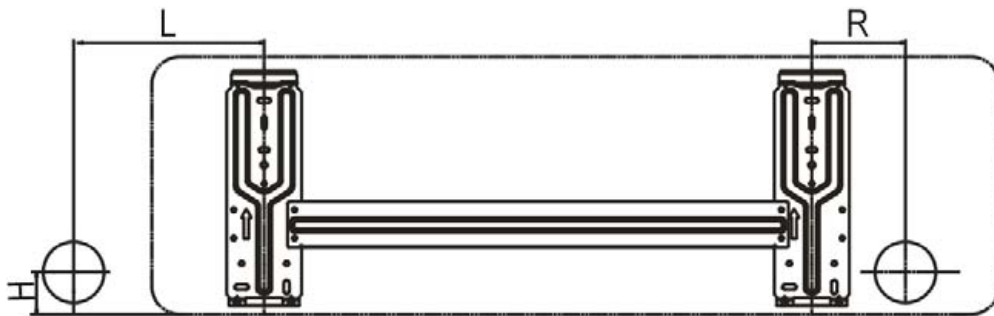

Model	L	R	H	Dimension of installation hole
WQ009GMFI22HLD	140mm	110mm	45mm	Φ65mm(2.56in)
WQ012GMFI22HLD	(5.5in)	(4.3in)	(1.8in)	

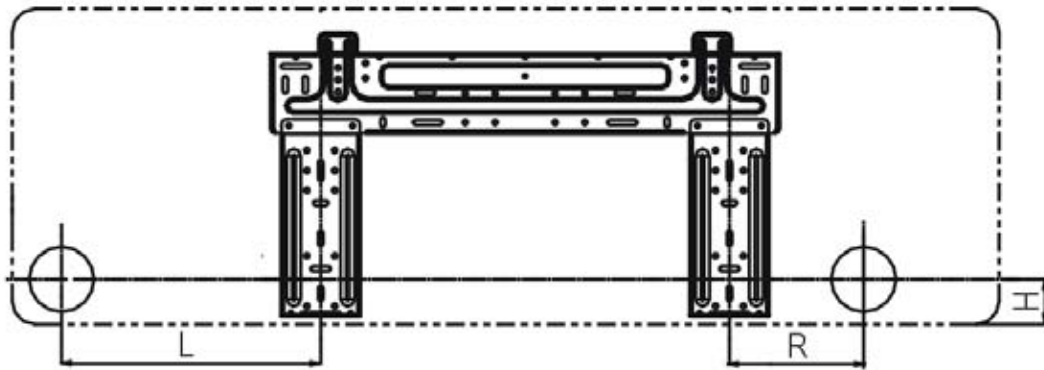

Model	L	R	H	Dimension of installation hole
WQ018GMFI22HLD	260mm (10.2in)	135mm (5.3in)	45mm (1.8in)	Φ65mm(2.56in)

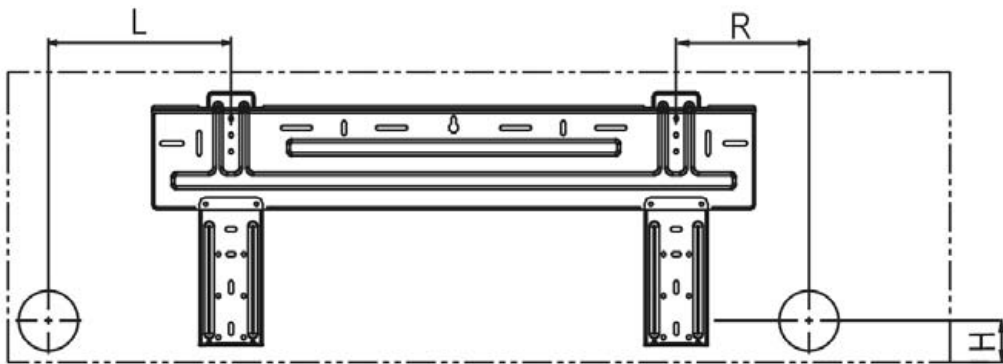

Model	L	R	H	Dimension of installation hole
WQ018GMFI22HLD	275mm (10.8in)	275mm (10.8in)	45mm (1.8in)	Φ65mm(2.56in)

3.2 Outdoor Unit

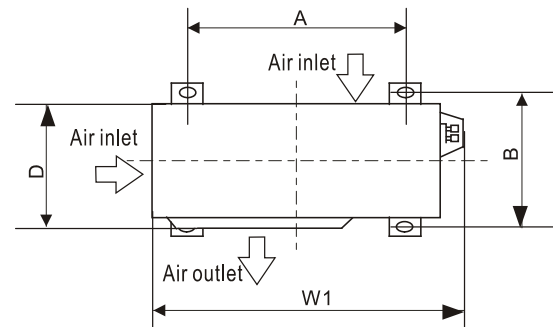
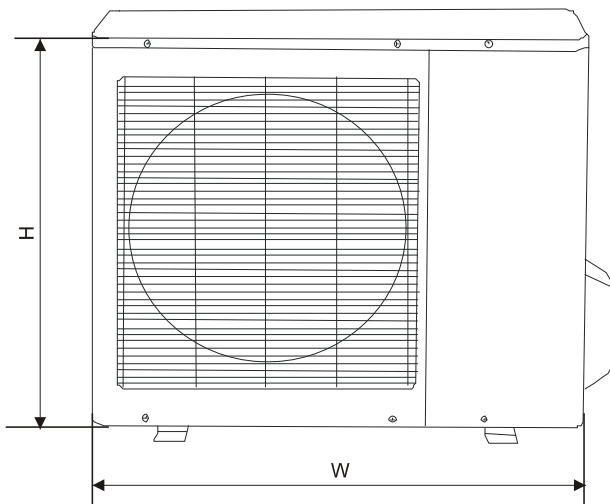
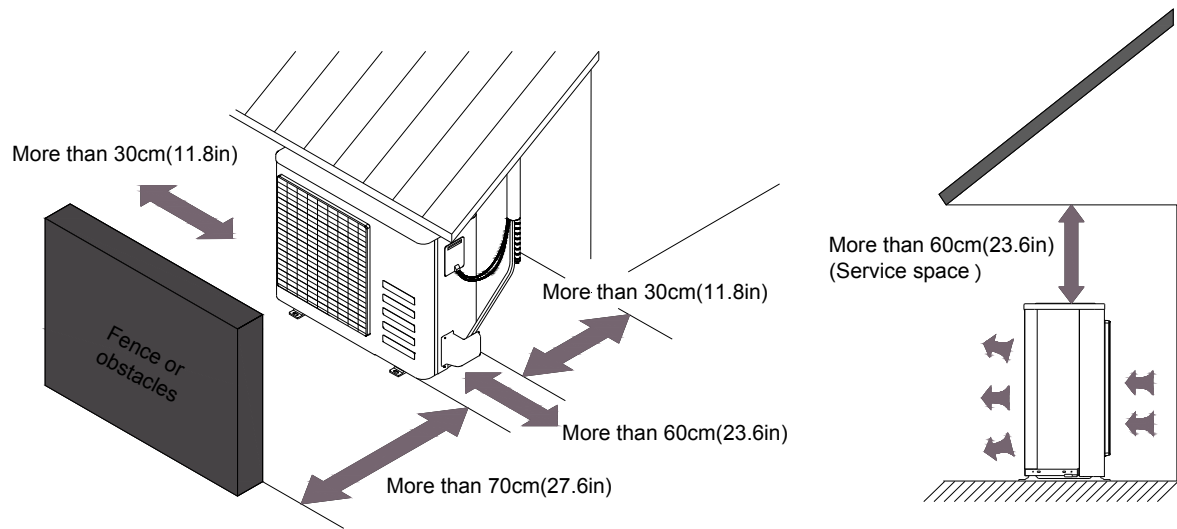

Note: The above drawing is only for reference. The appearance of your units may be different.

Model	W	D	H	W1	A	B
YN009GMFI22RPD	760mm	285mm	590mm	823mm	530mm	290mm
YN012GMFI22RPD	(29.9in)	(11.2in)	(23.2in)	(32.4in)	(20.9in)	(11.4in)
YN018GMFI22RPD	845mm	320mm	700mm	908mm	560mm	335mm
	(33.3in)	(12.6in)	(27.6in)	(35.7in)	(22.0in)	(13.2in)
YN024GMFI22RPD	900mm	315mm	860mm	980mm	590mm	333mm
	(36.7in)	(12.9in)	(35.1in)	(40in)	(24.1in)	(13.6in)

4. Refrigerant Cycle Diagram

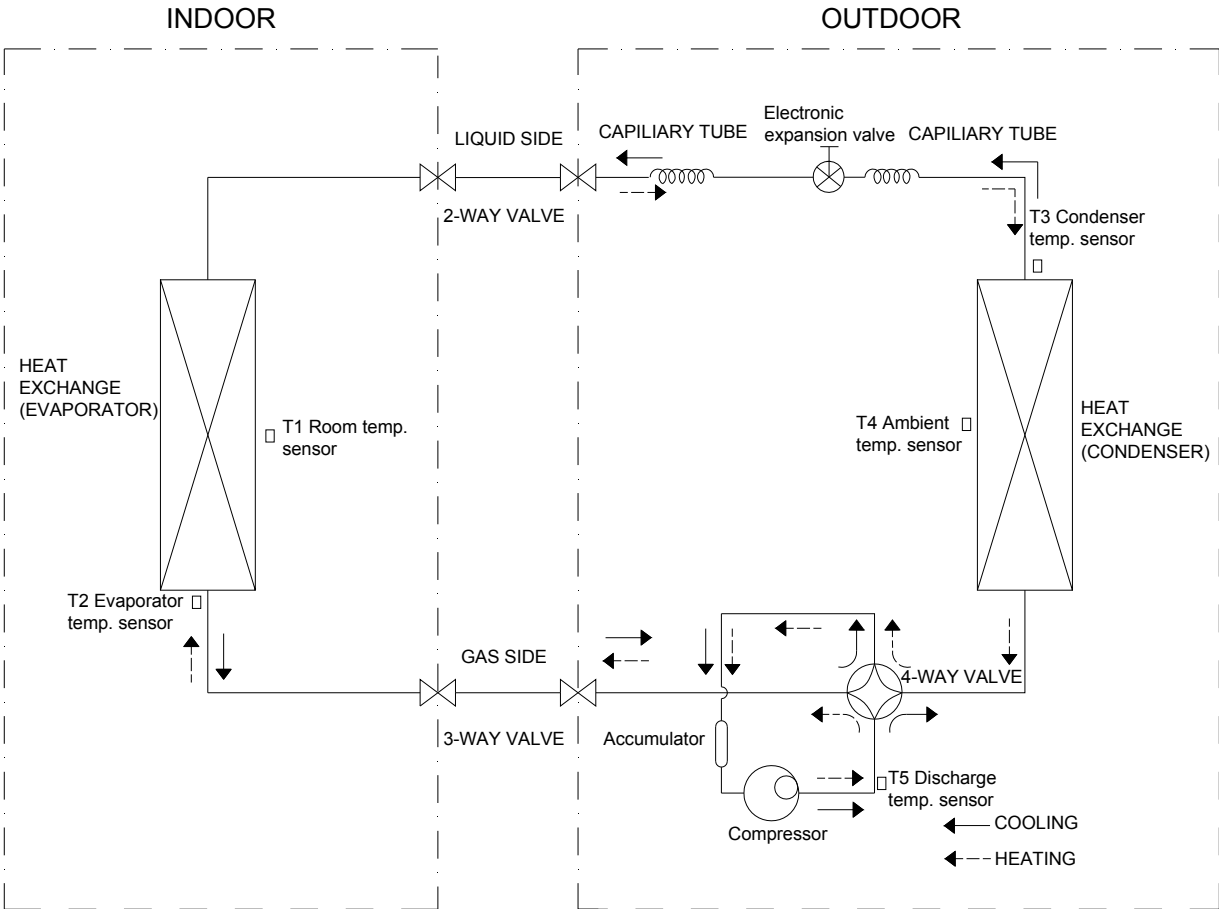

5. Wiring Diagram

5.1 Indoor Unit

WQ009GMFI22HLD, WQ012GMFI22HLD and WQ018GMFI22HLD

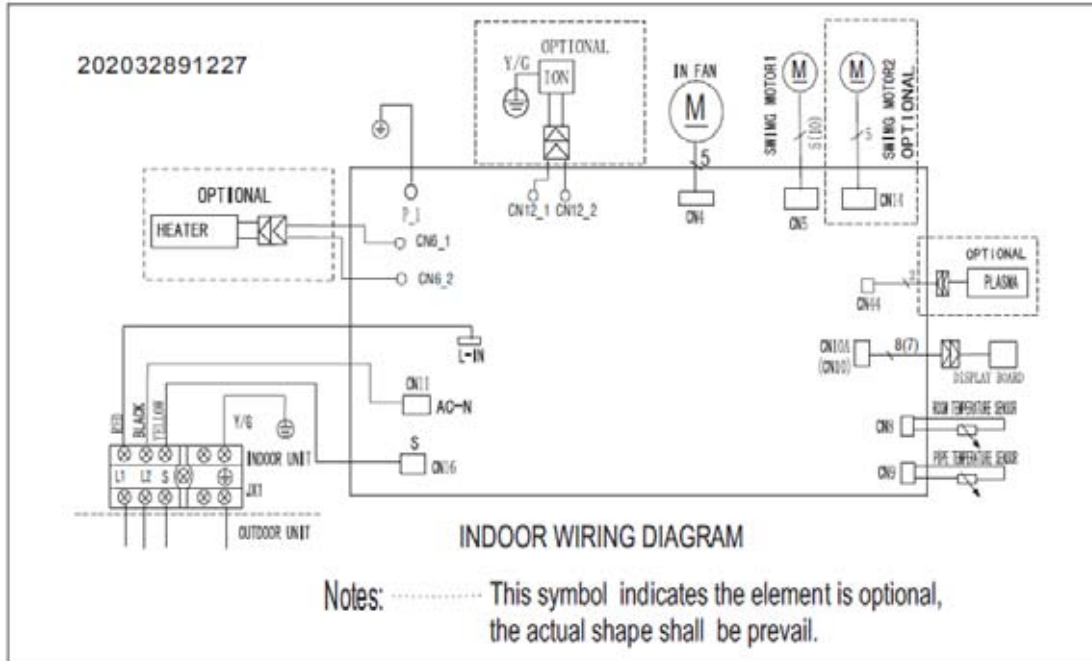

WQ024GMFI22HLD

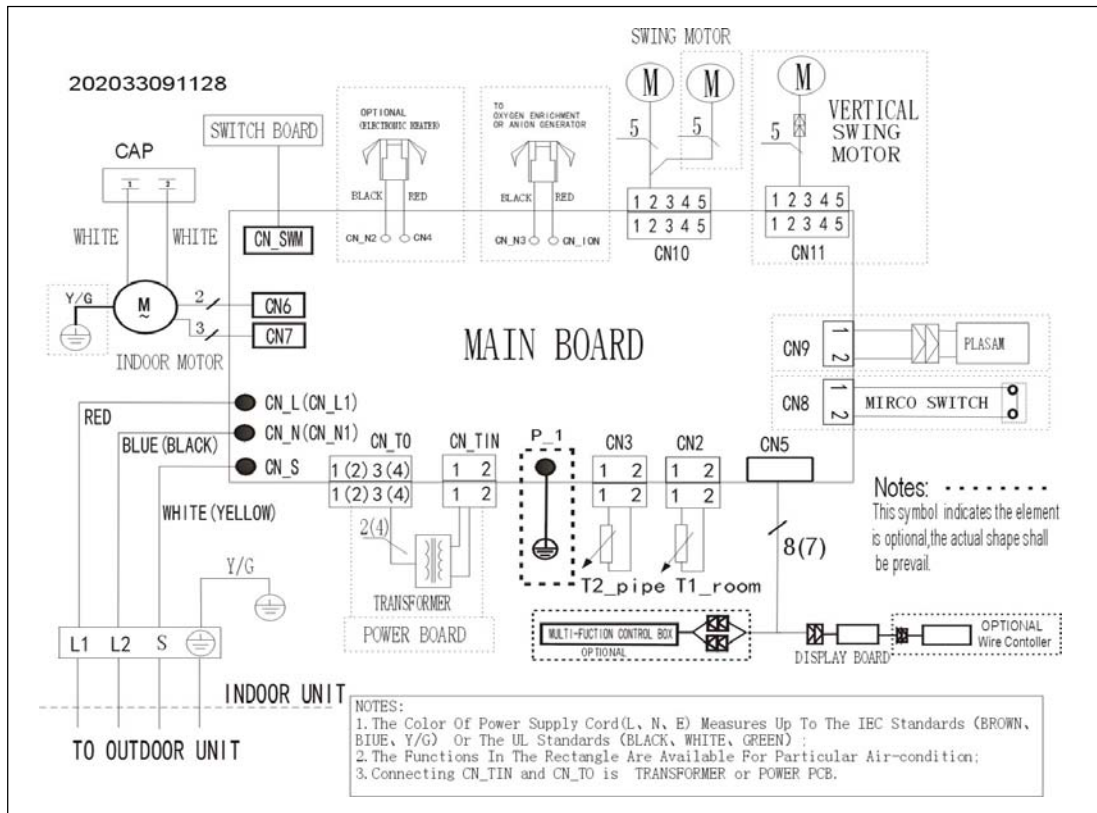

5.2 Outdoor Unit

YN009GMFI22RPD and YN012GMFI22RPD

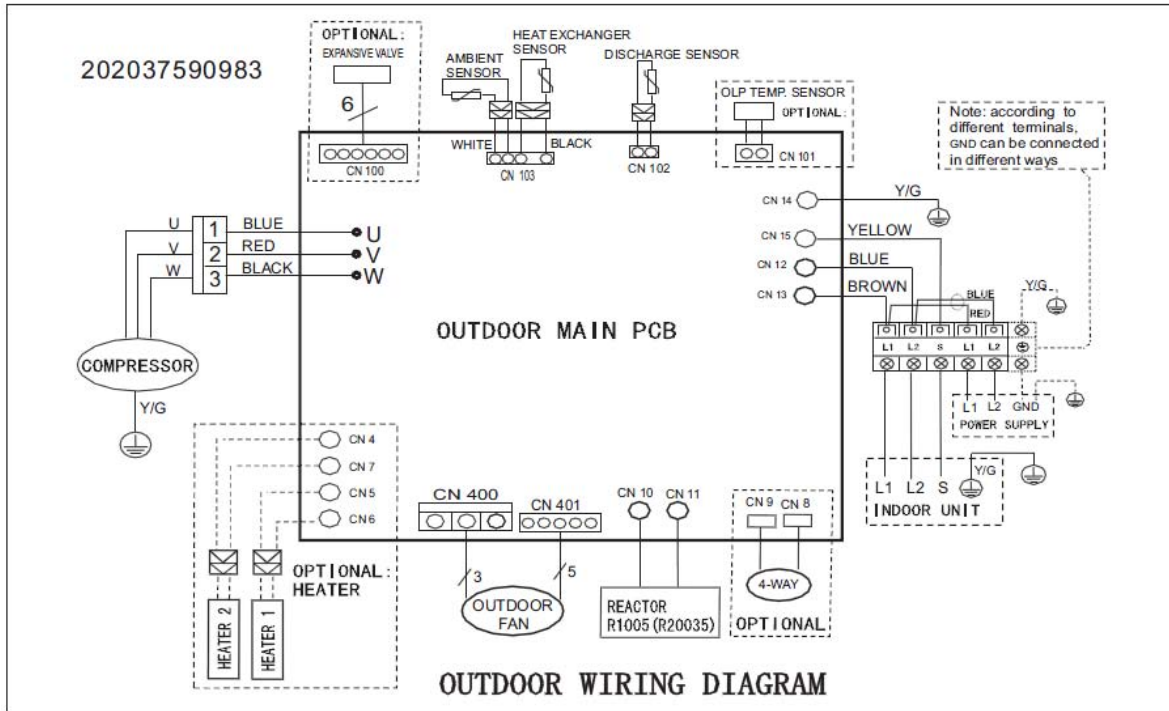

YN018GMFI22RPD

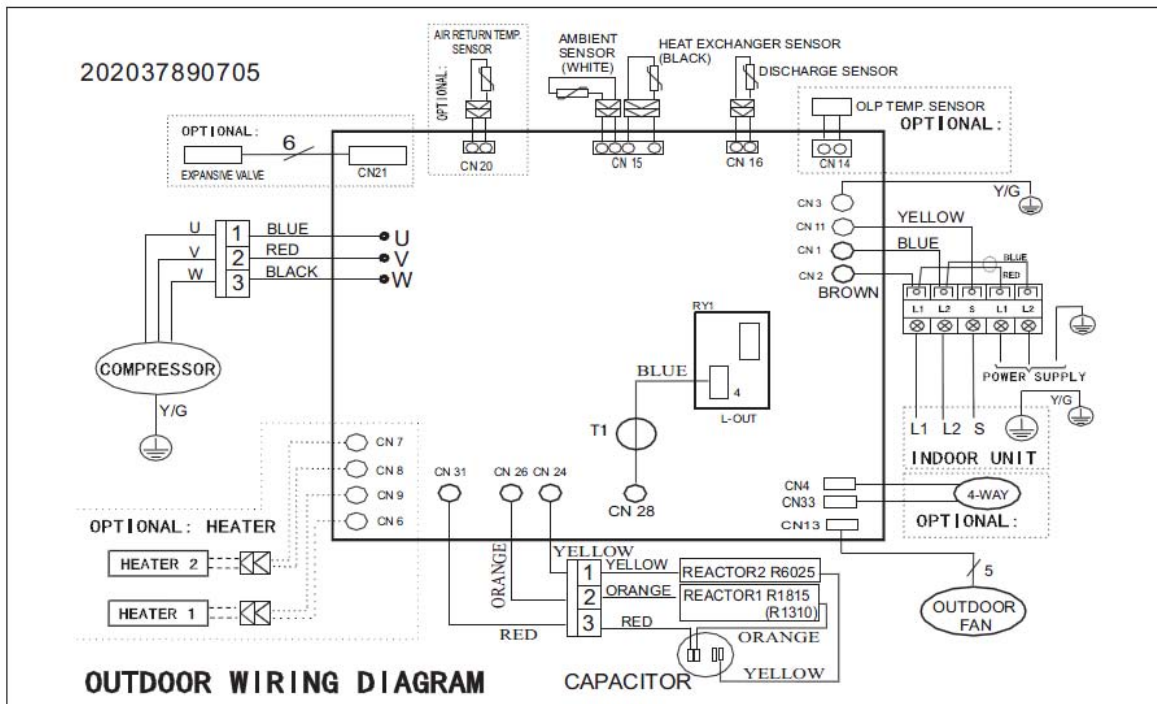

YN024GMFI22RPD

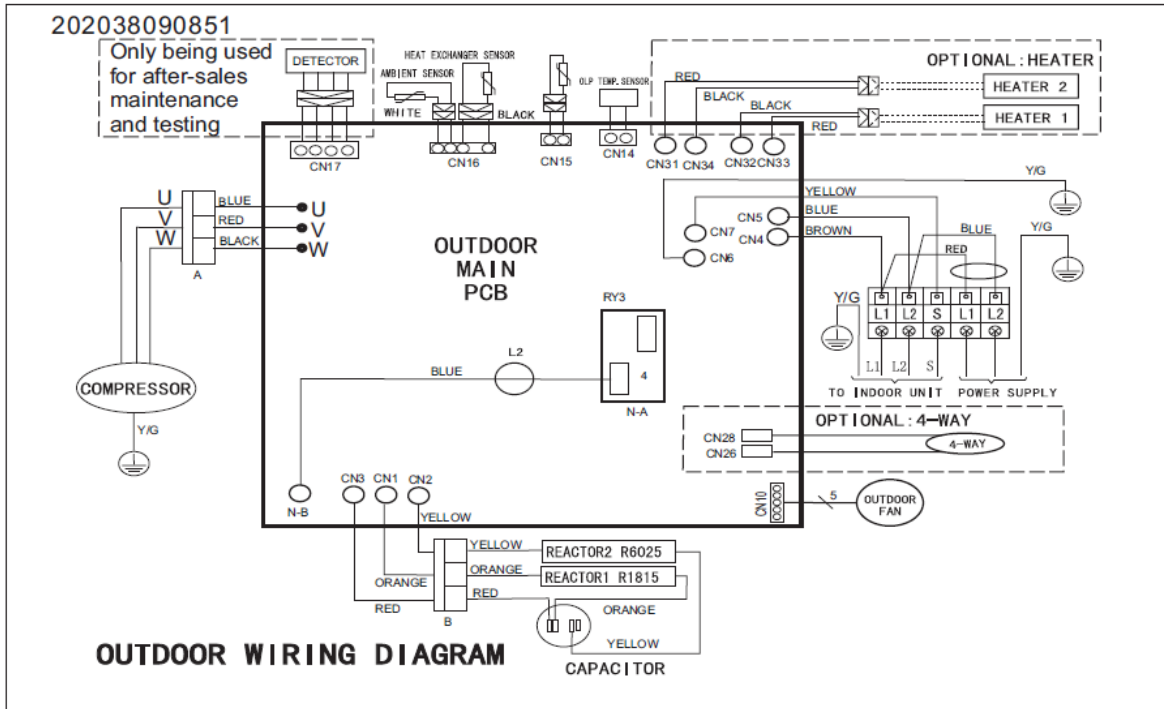

YN024GMFI22RPD

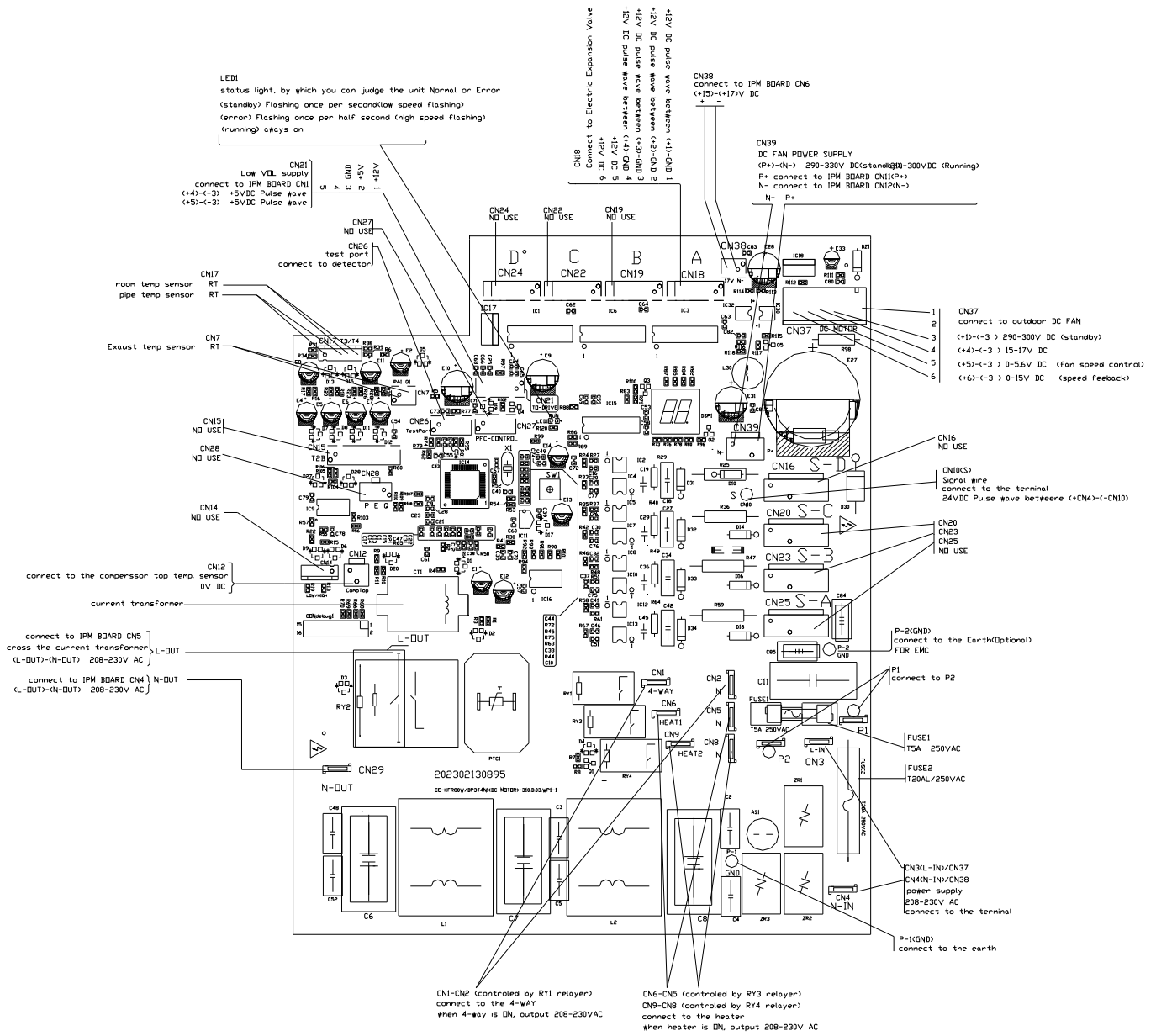

6 Installation Details

6.1 Wrench torque sheet for installation

Outside diameter		Torque	Additional tightening torque
Φ6.35mm	1/4in	1500N.cm(153kgf.cm)	1600N.cm(163kgf.cm)
Φ9.52mm	3/8in	2500N.cm(255kgf.cm)	2600N.cm(265kgf.cm)
Φ12.7mm	1/2in	3500N.cm(357kgf.cm)	3600N.cm(367kgf.cm)
Φ15.9mm	5/8in	4500N.cm(459kgf.cm)	4700N.cm(479kgf.cm)
Φ19mm	3/4in	6500N.cm(663kgf.cm)	6700N.cm(683kgf.cm)

6.2 Connecting the cables

The power cord should be selected according to the following specifications sheet.

Appliance Amps	AWG Wire Size
10	18
13	16
18	14
25	12
30	10

The cable size and the current of the fuse or switch are determined by the maximum current indicated on the nameplate which located on the side panel of the unit. Please refer to the nameplate before selecting the cable, fuse and switch.

6.3 Pipe length and the elevation

Models	Pipe size	
	Gas	Liquid
WYQ009: WQ009GMFI22HLD/ YN009GMFI22RPD	3/8in (Φ9.52mm)	1/4in (Φ6.35mm)
WYQ012: WQ012GMFI22HLD/ YN012GMFI22RPD	1/2in (Φ12.7mm)	1/4in (Φ6.35mm)
WYQ018: WQ018GMFI22HLD/ YN018GMFI22RPD	1/2in (Φ12.7mm)	1/4in (Φ6.35mm)
WYQ024: WQ024GMFI22HLD/ YN024GMFI22RPD	5/8in (Φ15.9mm)	3/8in (Φ9.52mm)

Models	Standard length	Max. Elevation	Max. Length A	Additional refrigerant
WQ009GMFI22HLD + YN009GMFI22RPD	7.5m (24.6ft)	10m (32.8ft)	25m (82.0ft)	15g/m (0.16oz/ft)
WQ012GMFI22HLD + YN012GMFI22RPD	7.5m (24.6ft)	10m (32.8ft)	25m (82.0ft)	15g/m (0.16oz/ft)
WQ018GMFI22HLD + YN018GMFI22RPD	7.5m (24.6ft)	20m (65.6ft)	30m (98.4ft)	15g/m (0.16oz/ft)
WQ024GMFI22HLD + YN024GMFI22RPD	7.5m (24.6ft)	25m (82.0ft)	50m (164ft)	30g/m (0.32oz/ft)

6.4 Installation for the first time

Air and moisture in the refrigerant system have undesirable effects as below:

- Pressure in the system rises.
- Operating current rises.
- Cooling or heating efficiency drops.
- Moisture in the refrigerant circuit may freeze and block capillary tubing.
- Water may lead to corrosion of parts in the refrigerant system.

Therefore, the indoor units and the pipes between indoor and outdoor units must be leak tested and evacuated to remove gas and moisture from the system.

Gas leak check (Soap water method):

Apply soap water or a liquid neutral detergent on the indoor unit connections or outdoor unit connections by a soft brush to

check for leakage of the connecting points of the piping. If bubbles come out, the pipes have leakage.

1. Air purging with vacuum pump

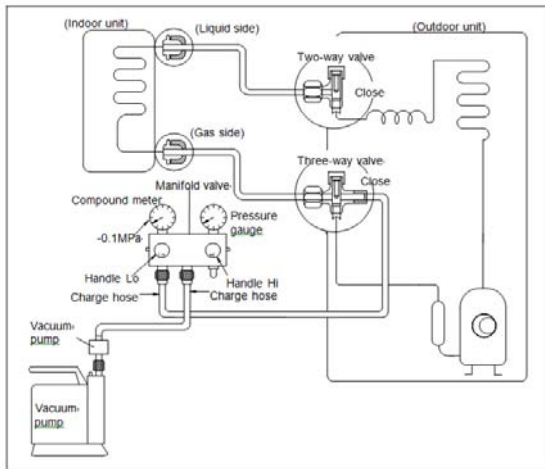

- 1) Completely tighten the flare nuts of the indoor and outdoor units, confirm that both the 2-way and 3-way valves are set to the closed position.
- 2) Connect the charge hose with the push pin of handle lo to the 3-way valves gas service port..
- 3) Connect the charge hose of handle hi connection to the vacuum pump.
- 4) Fully open the handle Lo of the manifold valve.
- 5) Operate the vacuum pump to evacuate.
- 6) Make evacuation for 30 minutes and check whether the compound meter indicates **-0.1Mpa(14.5Psi)**. If the meter does not indicate **-0.1Mpa(14.5Psi)** after pumping 30 minutes, it should be pumped 20 minutes more. If the pressure can't achieve **-0.1Mpa(14.5Psi)** after pumping 50 minutes, please check if there are some leakage points. Fully close the handle Lo valve of the manifold valve and stop the operation of the vacuum pump. Confirm that the gauge needle does not move (approximately 5 minutes after turning off the vacuum pump).
- 7) Turn the flare nut of the 3-way valves about 45° counterclockwise for 6 or 7seconds after the gas coming out, then tighten the flare nut again. Make sure the pressure display in the pressure indicator is a little higher than the atmosphere pressure. Then remove the charge hose from the 3 way

valve.

- 8) Fully open the 2 way valve and 3 way valve and securely tighten the cap of the 3 way valve.

2. Air purging by refrigerant

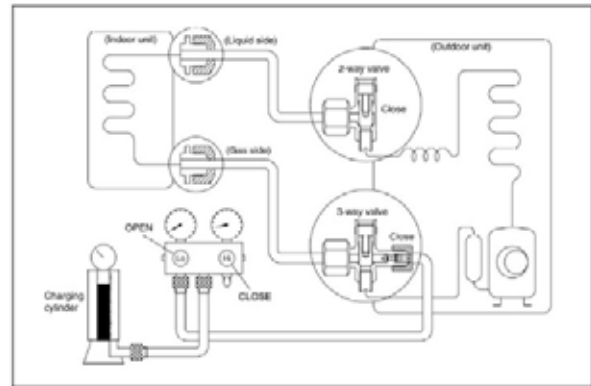

Procedure:

- 1). Confirm that both the 2-way and 3-way valves are set to the closed position.
- 2). Connect the charge set and a charging cylinder to the service port of the 3-way valve.
- 3). Air purging.
Open the valves on the charging cylinder and the charge set. Purge the air by loosening the flare nut on the 2-way valve approximately 45' for 3 seconds then closing it for 1 minute; repeat 3 times.
After purging the air, use a torque wrench to tighten the flare nut on the 2-way valve.
- 4). Check the gas leakage.
Check the flare connections for gas leakage.
- 5). Discharge the refrigerant.
Close the valve on the charging cylinder and discharge the refrigerant by loosening the flare nut on the 2-way valve approximately 45' until the gauge indicates **0.3Mpa(43.5Psi) to 0.5 Mpa(72.5Psi)**.
- 6). Disconnect the charge set and the charging cylinder, and set the 2-way and 3-way valves to the open position.
Be sure to use a hexagonal wrench to operate the valve stems.
- 7). Mount the valve stems nuts and the service port cap.
Be sure to use a torque wrench to tighten the

service port cap to a torque 18N·m.
Be sure to check the gas leakage.

6.5 Adding the refrigerant after running the system for many years

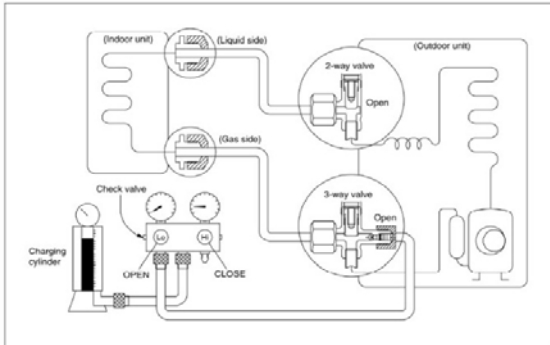

Procedure

- 1). Connect the charge hose to the 3-way service port, open the 2-way valve and the 3-way valve.
Connect the charge hose to the valve at the bottom of the cylinder. If the refrigerant is R410A, make the cylinder bottom up to ensure liquid charge.
- 2). Purge the air from the charge hose.
Open the valve at the bottom of the cylinder and press the check valve on the charge set to purge the air (be careful of the liquid refrigerant).
- 3) Put the charging cylinder onto the electronic scale and record the weight.
- 4) Operate the air conditioner at the cooling mode.
- 5) Open the valves (Low side) on the charge set and charge the system with liquid refrigerant.
- 6).When the electronic scale displays the proper weight (refer to the gauge and the pressure of the low side), disconnect the charge hose from the 3-way valve's service port immediately and turn off the air conditioner before disconnecting the hose.
- 7). Mount the valve stem caps and the service port
Use torque wrench to tighten the service port cap to a torque of 18N.m.
Be sure to check for gas leakage.

6.6 Re-installation while the indoor unit need to be repaired

1. Collecting the refrigerant into the outdoor unit

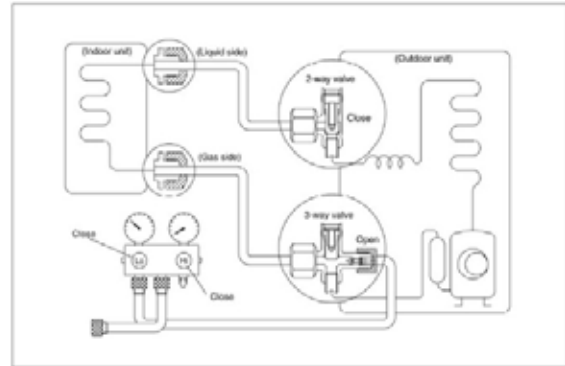

Procedure

- 1). Confirm that both the 2-way and 3-way valves are set to the opened position
Remove the valve stem caps and confirm that the valve stems are in the opened position.
Be sure to use a hexagonal wrench to operate the valve stems.
- 2). Connect the charge hose with the push pin of handle lo to the 3-way valves gas service port.
- 3). Air purging of the charge hose.
Open the handle Lo valve of the manifold valve slightly to purge air from the charge hose for 5 seconds and then close it quickly.
- 4). Set the 2-way valve to the close position.
- 5). Operate the air conditioner at the cooling cycle and stop it when the gauge indicates **0.1Mpa(14.5Psi)**.
- 6). Set the 3-way valve to the closed position immediately
Do this quickly so that the gauge ends up indicating **0.3Mpa(43.5Psi) to 0.5 Mpa(72.5Psi)**.
Disconnect the charge set, and tighten the 2-way and 3-way valve's stem nuts.
Use a torque wrench to tighten the 3-way valves service port cap to a torque of 18N.m.
Be sure to check for gas leakage.

2. Air purging by the refrigerant

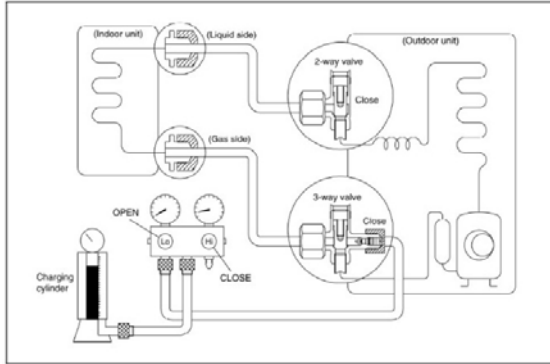

Procedure:

- 1). Confirm that both the 2-way and 3-way valves are set to the closed position.
- 2). Connect the charge set and a charging cylinder to the service port of the 3-way valve. Leave the valve on the charging cylinder closed.
- 3). Air purging.

Open the valves on the charging cylinder and the charge set. Purge the air by loosening the flare nut on the 2-way valve approximately 45° for 3 seconds then closing it for 1 minute; repeat 3 times.

After purging the air, use a torque wrench to tighten the flare nut on the 2-way valve.

- 4). Check the gas leakage

Check the flare connections for gas leakage.

- 5). Discharge the refrigerant.

Close the valve on the charging cylinder and discharge the refrigerant by loosening the flare nut on the 2-way valve approximately 45° until the gauge indicates **0.3Mpa(43.5Psi) to 0.5 Mpa(72.5Psi)**.

- 6). Disconnect the charge set and the charging cylinder, and set the 2-way and 3-way valves to the open position

Be sure to use a hexagonal wrench to operate the valve stems.

- 7). Mount the valve stems nuts and the service port cap

Be sure to use a torque wrench to tighten the service port cap to a torque 18N.m.

Be sure to check the gas leakage.

6.7 Re-installation while the outdoor unit need to be repaired

1. Evacuation for the whole system

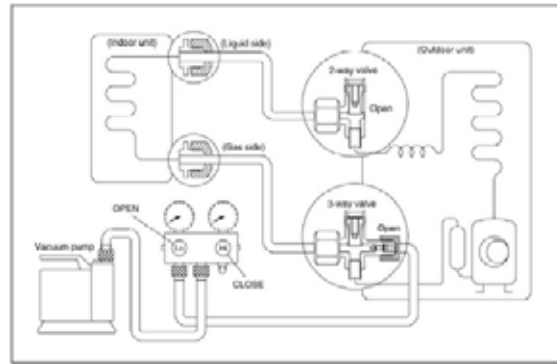

Procedure:

- 1). Confirm that both the 2-way and 3-way valves are set to the opened position.
- 2). Connect the vacuum pump to 3-way valve's service port.
- 3). Evacuation for approximately one hour. Confirm that the compound meter indicates **-0.1Mpa(14.5Psi)**.
- 4). Close the valve (Low side) on the charge set, turn off the vacuum pump, and confirm that the gauge needle does not move (approximately 5 minutes after turning off the vacuum pump).
- 5). Disconnect the charge hose from the vacuum pump.

2. Refrigerant charging

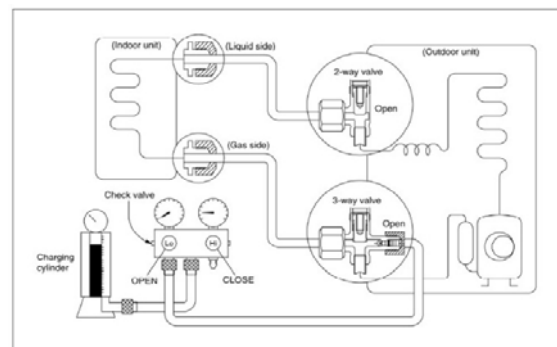

Procedure:

- 1). Connect the charge hose to the charging cylinder, open the 2-way valve and the 3-way valve

Connect the charge hose which you disconnected from the vacuum pump to the valve at the bottom of the cylinder. If the refrigerant is R410A, make the cylinder bottom up to ensure liquid charge.

- 2). Purge the air from the charge hose
Open the valve at the bottom of the cylinder and press the check valve on the charge set to purge the air (be careful of the liquid refrigerant).
- 3) Put the charging cylinder onto the electronic scale and record the weight.
- 4). Open the valves (Low side) on the charge set and charge the system with liquid refrigerant
If the system cannot be charge with the specified amount of refrigerant, or can be charged with a little at a time (approximately 150g each time) , operating the air conditioner in the cooling cycle; however, one time is not sufficient, wait approximately 1 minute and then repeat the procedure.
- 5).When the electronic scale displays the proper weight, disconnect the charge hose from the 3-way valve's service port immediately
If the system has been charged with liquid refrigerant while operating the air conditioner, turn off the air conditioner before disconnecting the hose.
- 6). Mounted the valve stem caps and the service port. Use torque wrench to tighten the service port cap to a torque of 18N.m. Be sure to check for gas leakage.

7. Operation Characteristics

Temperature Mode	Cooling operation	Heating operation	Drying operation
Room temperature	17°C ~ 32°C (62°F ~ 90°F)	0°C ~ 30°C (32°F ~ 86°F)	10°C ~ 32°C (50°F ~ 90°F)
Outdoor temperature	0°C ~ 50°C (32°F ~ 122°F)	-15°C ~ 30°C (5°F ~ 86°F)	0°C ~ 50°C (32°F ~ 122°F)
	-15°C ~ 50°C (5°F ~ 122°F) (For the models with low temperature cooling system)		

$$\Delta T(^{\circ}\text{F}) = \frac{9\Delta T(^{\circ}\text{C})}{5} + 32$$

CAUTION:

1. If the air conditioner is used beyond the above conditions, certain safety protection features may come into operation and cause the unit to operate abnormally.
2. The room relative humidity should be less than 80%. If the air conditioner operates beyond this figure, the surface of the air conditioner may attract condensation. Please set the vertical air flow louver to its maximum angle (vertically to the floor), and set HIGH fan mode.
3. The optimum performance will be achieved during this operating temperature zone.

8. Electronic Function





8.1 Abbreviation

- T1: Indoor room temperature
- T2: Coil temperature of evaporator
- T3: Coil temperature of condenser
- T4: Outdoor ambient temperature
- T5: Compressor discharge temperature

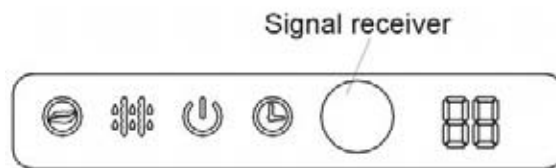
8.2 Display function

8.2.1 Icon explanation on indoor display board.



	ION indication lamp(optional function): This lamp illuminates when Clean Air feature is activated.
	DEFROST indication lamp(For cooling & heating models only): Lights up when the air conditioner starts defrosting automatically or when the warm air control feature is activated in heating operation.
	OPERATION indication lamp: This lamp illuminates when the air conditioner is in operation.
	TIMER indication lamp: Lights up during Timer operation.
	Temperature indicator: Displays the temperature settings when the air conditioner is operational. Displays the malfunction code.

8.3 Main Protection

8.3.1 Three minutes delay at restart for compressor

1 minute delay for the 1st time stand-up and 3 minutes delay for others.

8.3.2 Temperature protection of compressor top

The unit will stop working when the compressor top temp. protector cut off, and will restart after the compressor top temp. protector restart.

8.3.3 Temperature protection of compressor discharge

When the compressor discharge temp. is getting higher, the running frequency will be limited as below rules:

---Compressor discharge temp.

$T5 > 115^{\circ}\text{C} (239^{\circ}\text{F})$ for 5s, compressor stops.

--- $108^{\circ}\text{C} (226^{\circ}\text{F}) < T5 < 115^{\circ}\text{C} (239^{\circ}\text{F})$, decrease the frequency to the lower level every 3 minutes.

--- $90^{\circ}\text{C} (194^{\circ}\text{F}) < T5 < 105^{\circ}\text{C} (221^{\circ}\text{F})$, keep running at the current frequency.

---- $T5 < 90^{\circ}\text{C} (194^{\circ}\text{F})$, no limit for frequency.

8.3.4 Fan speed is out of control

When Indoor fan speed keeps too low (300RPM) for certain time, the unit will stop and the LED will display the failure

8.3.5 Inverter module protection

The Inverter module has a protection function about current, voltage and temperature. If these protections happen, the corresponding code will display on indoor unit and the unit will stop working.

8.3.6 Indoor fan delayed open function

When the unit starts up, the louver will be active immediately and the indoor fan will open 10s later.

If the unit runs in heating mode, the indoor fan will be also controlled by anti-cold wind function.

8.3.7 Compressor preheating functions

Preheating permitting condition:

If $T4$ (outdoor ambient temperature) $< 3^{\circ}\text{C} (37.4^{\circ}\text{F})$ and the machine connects to power supply newly or if $T4 < 3^{\circ}\text{C} (37.4^{\circ}\text{F})$ and compressor has stopped for over 3 hours, the compressor heating cable will work.

Preheating mode:

A weak current flow through the coil of compressor from the wiring terminal of the compressor, then the compressor is heated without operation.

Preheating release condition:

If $T4 > 5^{\circ}\text{C} (41^{\circ}\text{F})$ or the compressor starts running, the preheating function will stop.

8.3.8 Zero crossing detection error protection

If AC detects time interval is not correct for continuous 240s, the unit will stop and the LED will display the failure. The correct zero crossing signal time interval should be between 6-13ms.

8.3.9 Condenser temperature protection

--- $55^{\circ}\text{C} (131^{\circ}\text{F}) < T3 < 60^{\circ}\text{C} (140^{\circ}\text{F})$, the compressor frequency will decrease to the lower level until to F1 and then runs at F1. If $T3 < 54^{\circ}\text{C} (129.2^{\circ}\text{F})$, the compressor will keep running at the current frequency.

--- $T3 < 52^{\circ}\text{C} (125.6^{\circ}\text{F})$, the compressor will not limit the frequency and resume to the former frequency.

--- $T3 > 60^{\circ}\text{C} (140^{\circ}\text{F})$ for 5 seconds, the compressor will stop until $T3 < 52^{\circ}\text{C} (125.6^{\circ}\text{F})$.

8.3.10 Evaporator temperature protection

--- $T2 < 0^{\circ}\text{C} (32^{\circ}\text{F})$, the compressor will stop and restart when $T2 \geq 5^{\circ}\text{C} (41^{\circ}\text{F})$.

--- $0^{\circ}\text{C} (32^{\circ}\text{F}) \leq T2 < 4^{\circ}\text{C} (39.2^{\circ}\text{F})$, the compressor frequency will be limited and decreased to the lower level

--- $4^{\circ}\text{C} (39.2^{\circ}\text{F}) \leq T2 \leq 7^{\circ}\text{C} (44.6^{\circ}\text{F})$, the compressor will keep the current frequency.

--- $T2 > 7^{\circ}\text{C} (44.6^{\circ}\text{F})$, the compressor frequency will not be limited.

8.4 Operation Modes and Functions

8.4.1 Fan mode

- (1) Outdoor fan and compressor stop.
- (2) Temperature setting function is disabled, and no setting temperature is displayed.
- (3) Indoor fan can be set to high/med/low/auto.
- (4) The louver operates same as in cooling mode.
- (5) Auto fan:

For 9K, 12K and 18K Models:

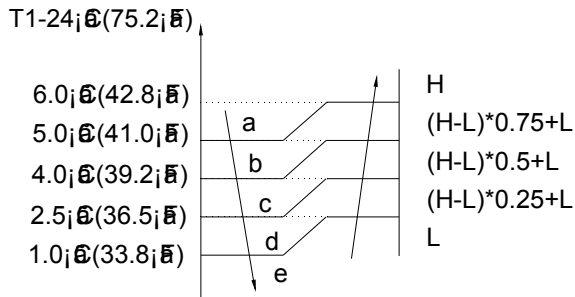

For 24K model:

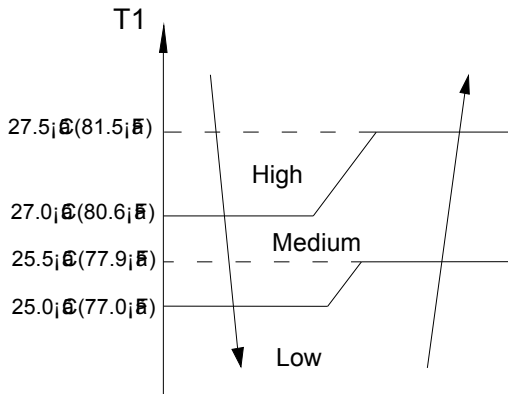

8.4.2 Cooling Mode

8.4.2.1 Compressor running rules

The maximum operation frequency of compressor after starting submits to following rule.

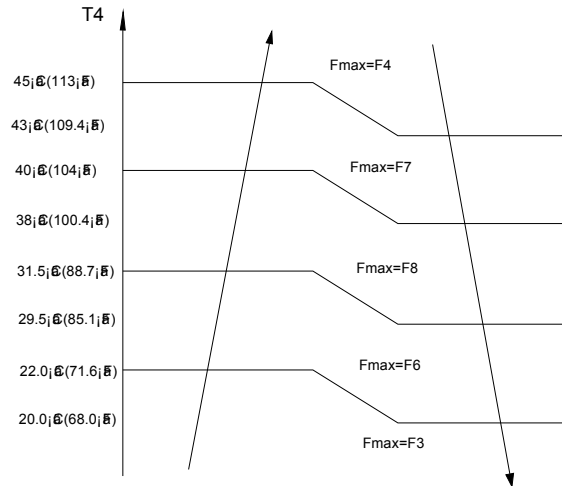

F_{max} : The maximum operation frequency of compressor.

F1~F8: The detailed value of the compressor operation frequency.

Meanwhile, the maximum frequency is limited by the indoor fan speed.

Indoor fan speed	Maximum frequency
High speed / turbo function	No limit
Silent mode	Fixed at F3

If users switch on AC by remote controller, the compressor will run at the F_{max} frequency for 7 minutes according to the outdoor ambient temp. During the 7 minutes, the frequency limitation is active. 7 minutes later, the compressor running frequency will be controlled as below:

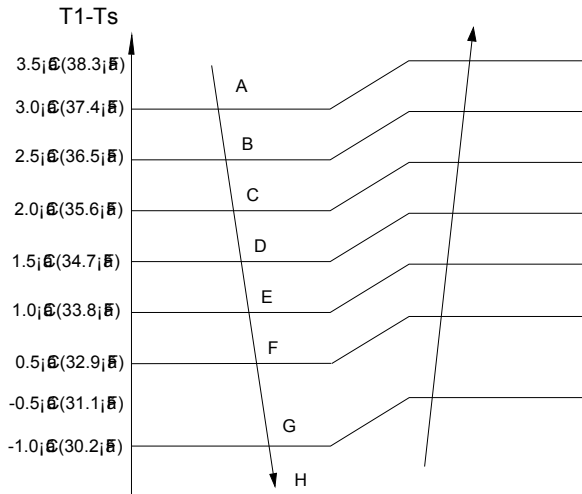

While the zones of A,B,C... are corresponding to different compressor running frequency.

Note:

When T1-Ts keeps in the same temp. zone for 3 minutes, the compressor will run as the below rules:

A~E: Increase the frequency to the higher level until to F8.

F: Keep the current frequency.

G: Decrease the frequency to the lower level until to F1.

H: Run at F1 for 1h.(if T1-Ts<-2°C(28.4°F), the compressor will stop)

Meanwhile, the compressor running frequency is limited by the current.

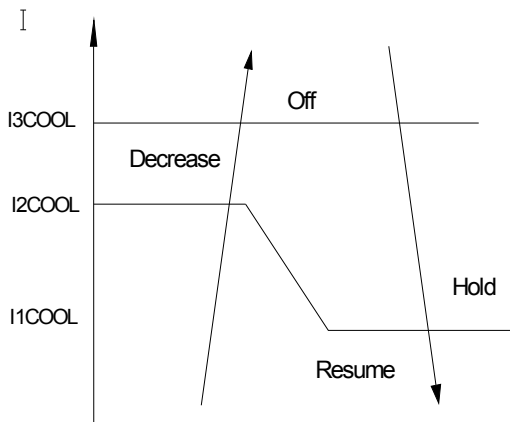

I3COOL, I2COOL, I1COOL mean different running current value.

Off: Compressor stops.

Decrease: Decrease the running frequency to the lower level.

Hold: Keep the current frequency.

Resume: No limitation for frequency.

Note:

When AC is in “hold” zone for 3 minutes, the compressor frequency will rise to the higher level.(frequency will increase twice at most)

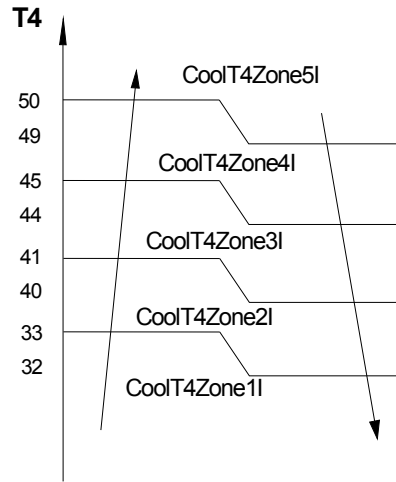

8.4.2.2 Outdoor fan running rules

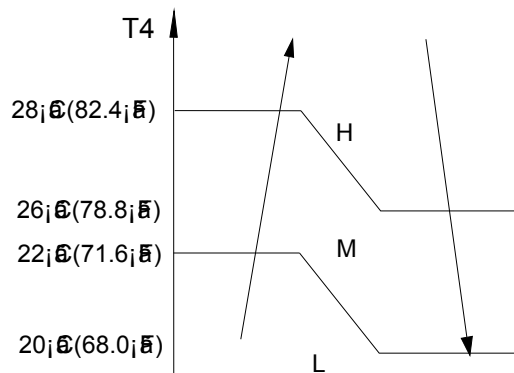

8.4.2.3 Indoor fan running rules

In cooling mode, indoor fan runs all the time and the speed can be selected as high, medium, low, auto and silent mode. When the compressor is running, the indoor fan is controlled as below:

For 9K, 12K and 18K Models:

Setting Fan speed	T1-Ts	Actual fan speed
H	4.5	H+(H=L+G)
	3.0	H (=H)
	1.5	H-(H=L+G)
M	4.5	M+(M=L+Z)
	3.0	M(M=L)
	1.5	M-(M=L+Z)
L	4.5	L+(L=L+D)
	3.0	L(L=L)
	1.5	L-(L=L+D)

Auto fan running rules:
9K, 12K and 18K models:

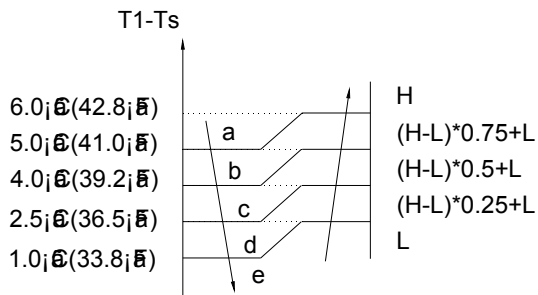

24K model:

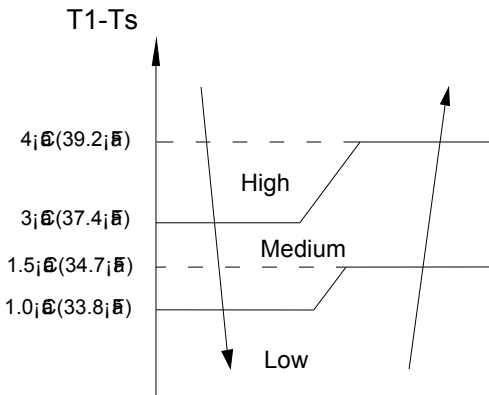

8.4.3 Heating Mode

8.4.3.1 Compressor running rules

The maximum operation frequency of the compressor after starting submits to the following rule.

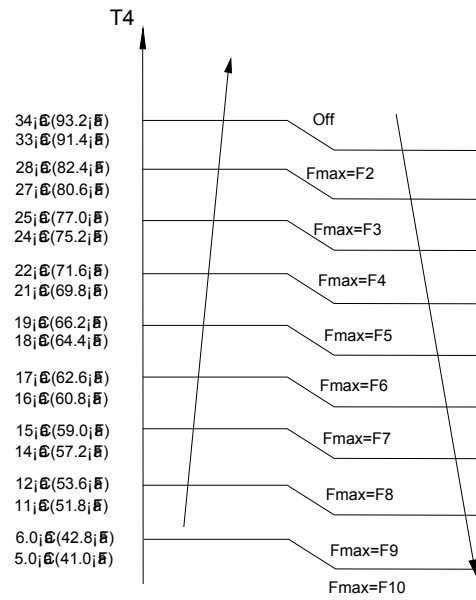

Fmax: The maximum operation frequency of compressor.

F1~F8: The detailed value of the compressor operation frequency.

If users switch on AC by remote controller, the compressor will run at the Fmax frequency for 7 minutes according to outdoor ambient temp. During the 7 minutes, the frequency limitation is active.

7 minutes later, the compressor running frequency will be controlled as below:

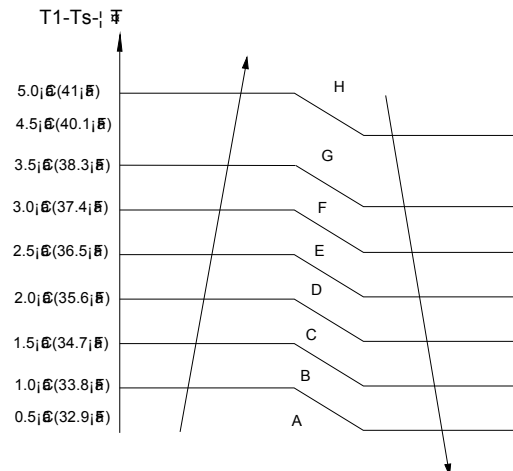

While the zones of A,B,C... are corresponding to different compressor running frequency.

$\Delta T = 0^\circ \text{C} (32^\circ \text{F})$ as default.

Note:

When T1-Ts keeps in the same temp. zone for

3 minutes, the compressor will run as the below rules:

A~E: Increase the frequency to the higher level until to F10.

F: Keep the current frequency.

G: Decrease the frequency to the lower level until to F1.

H: Run at F1 for 1h.(if $T1-Ts-\Delta T > 6^{\circ}\text{C}(42.8^{\circ}\text{F})$, the compressor will stop)

Meanwhile, the compressor running frequency is limited by the current.

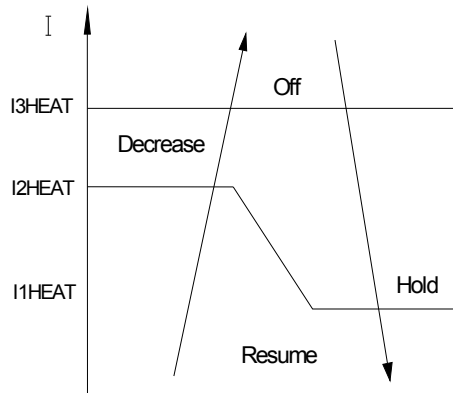

I3HEAT, I2HEAT, I1HEAT mean different running current value.

Off: Compressor stops.

Decrease: Decrease the running frequency to the lower level.

Hold: Keep the current frequency.

Resume: No limitation for frequency.

Note:

When AC is in "hold" zone for 3 minutes, the compressor frequency will rise to the higher level. (The frequency will increase twice at most)

8.4.3.2 Outdoor fan running rules

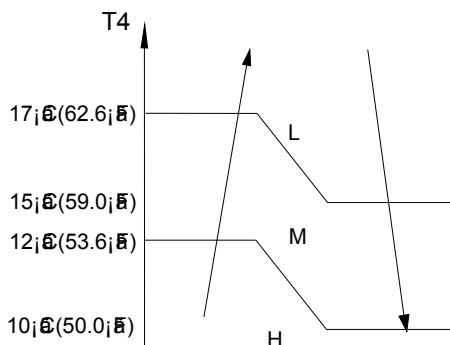

8.4.3.3 Indoor fan running rules

Indoor fan speed can be set as high, medium, low, silent mode or auto grade. During all the fan speeds, the anti-cold-wind function is preferential. If the compressor stops caused by the room temperature rising, the indoor fan will run at super breeze. When the compressor is running, the indoor fan is controlled as below:

Setting fan speed	T1-Ts	Actual fan speed
H	-1.5	H+(H+G)
	-3.0	H(L=H)
	-4.5	H+(H+H+G)
M	-1.5	M-(M-M-Z)
	-3.0	M(M=M)
	-4.5	M+(M+M+Z)
L	-1.5	L-(L=L-D)
	-3.0	L(L=L)
	-4.5	L+(L=L+D)

Auto fan action in heating mode.

For 9K, 12K and 18K models:

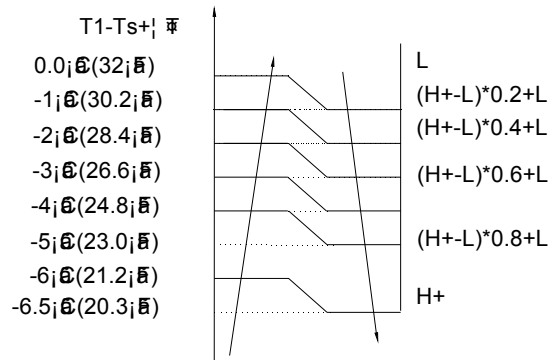

For 24K model:

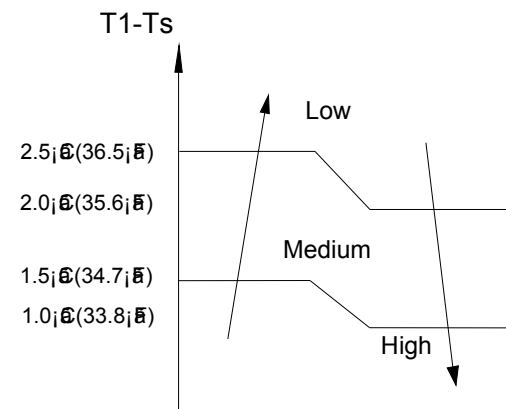

8.4.3.4 Defrosting mode

Condition of defrosting:

---- $T_4 > 0^{\circ}\text{C}(32^{\circ}\text{F})$,

When the units are running, if the following two items are satisfied, the units start defrosting:

The units run with $T_3 < 3^{\circ}\text{C}(37.4^{\circ}\text{F})$, for 40 minutes and T_3 keeps lower than $\text{TCDI}^{\circ}\text{C}$ for more than 3 minutes.

The units run with $T_3 < 3^{\circ}\text{C}(37.4^{\circ}\text{F})$ for 80 minutes and T_3 keeps lower than $\text{TCDI} + 2^{\circ}\text{C}(35.6^{\circ}\text{F})$ for more than 3 minutes.

---- $T_4 < 0^{\circ}\text{C}(32^{\circ}\text{F})$,

If the 1st condition and 2nd condition items are satisfied, then the program judges if T_2 has decreased more than $5^{\circ}\text{C}(41^{\circ}\text{F})$. When T_2 has decreased more than $5^{\circ}\text{C}(41^{\circ}\text{F})$, enter the defrosting mode.

----No matter what value T_4 is, if the machine runs with $T_3 < 3^{\circ}\text{C}(37.4^{\circ}\text{F})$ for more than 120 minutes and T_3 keeps lower than $\text{TCDI} + 4^{\circ}\text{C}(39.2^{\circ}\text{F})$ for more than 3 minutes, the machine will enter defrosting mode no matter if T_2 drops more than $5^{\circ}\text{C}(41^{\circ}\text{F})$ or not.

Condition of ending defrosting:

If any one of the following items is satisfied, the defrosting will finish and the machine will turn to normal heating mode.

---- T_3 rises to be higher than $\text{TCDE} + 1^{\circ}\text{C}$.

---- T_3 keeps to be higher than $\text{TCDE} + 2^{\circ}\text{C}$ for 80 seconds.

----The machine has run for 10 minutes in defrosting mode.

Defrosting action:

For 9k,12k models:

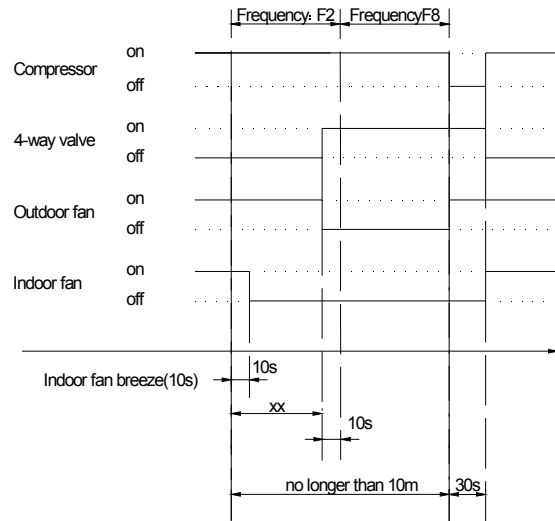

xx=60s.

For 18k,24k models:

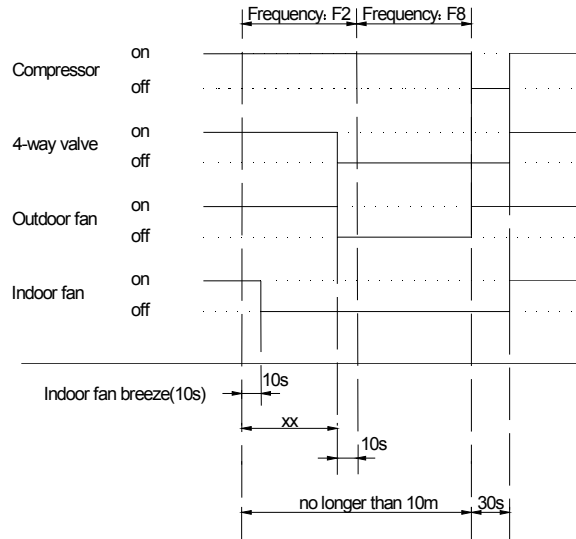

XX=90.

8.4.3.5 Evaporator coil temperature protection

---- $T_2 > \text{TEH}2^{\circ}\text{C}$, the compressor running frequency decreases to the lower level and runs for 20s.

When the frequency decreases to F_2 and the T_2 is still over $\text{TEH}2^{\circ}\text{C}$ for 3 minutes, the compressor will stop.

---- $T_2 < 48^{\circ}\text{C}(118.4^{\circ}\text{F})$ or T_2 stays in $48^{\circ}\text{C}(118.4^{\circ}\text{F}) \sim \text{TEH}2^{\circ}\text{C}$ for 6 minutes, the frequency will not be limited by T_2 .

---- $T_2 > 60^{\circ}\text{C}(140^{\circ}\text{F})$, the compressor will stop

and restart when $T_2 < 48^\circ\text{C}$ (118.4°F).

8.4.4 Auto-mode

This mode can be chosen with remote controller and the setting temperature can be changed between 17°C (62.6°F)~ 30°C (86°F). In auto mode, the machine will choose cooling, heating or fan-only mode according to ΔT ($\Delta T = T_1 - T_s$).

$\Delta T = T_1 - T_s$	Running mode
$\Delta T > 1^\circ\text{C}$ (33.8°F)	Cooling
-1°C (30.2°F) $< \Delta T \leq 1^\circ\text{C}$ (33.8°F)	Fan-only
$\Delta T \leq -1^\circ\text{C}$ (30.2°F)	Heating

Indoor fan will run at auto fan of the relevant mode.

The louver operates same as in relevant mode. If the machine switches mode between heating and cooling, the compressor will keep stopping for 15 minutes and then choose mode according to $T_1 - T_s$.

If the setting temperature is modified, the machine will choose running function again.

8.4.5 Drying mode

8.4.5.1 Indoor fan speed is fixed at breeze and can't be changed. The louver angle is the same as in cooling mode.

8.4.5.2 Compressor running rules

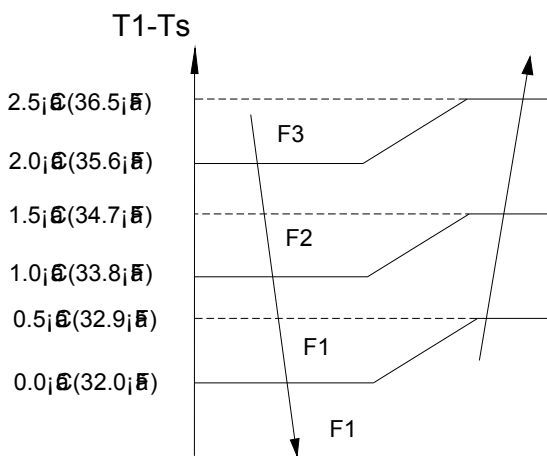

8.4.5.3 Low indoor room temperature protection

In drying mode, if room temperature is lower than 10°C (50°F), the compressor will stop and not resume until room temperature exceeds 12°C (53.6°F).

8.4.5.4 Evaporator anti-freezing protection, condenser high temperature protection and outdoor unit frequency limit are active and the same as that in cooling mode.

8.4.5.5 The outdoor fan operates the same as in cooling mode.

8.4.6 Forced operation function

8.4.6.1 Enter forced operation function:

When the machine is off, pressing the touch button will carry the machine to forced auto mode. If pressing the button once again within 5 seconds, the machine will turn into forced cooling mode.

In forced auto, forced cooling or any other operation mode, pressing touch button will turn off the machine.

8.4.6.2 In forced operation mode, all general protections and remote control are available.

8.4.6.3 Operation rules:

Forced cooling mode:

The compressor runs at F2 frequency and indoor fan runs as breeze. After running for 30 minutes, the machine will turn to auto mode as 24°C (75.2°F) setting temperature.

Forced auto mode:

The action of forced auto mode is the same as normal auto mode with 24°C (75.2°F) setting temperature.

8.4.7 Timer function

8.4.7.1 Timing range is 24 hours.

8.4.7.2 Timer on. The machine will turn on automatically when reaching the setting time.

8.4.7.3 Timer off. The machine will turn off automatically when reaching the setting time.

8.4.7.4 Timer on/off. The machine will turn on automatically when reaching the setting "on" time, and then turn off automatically when reaching the setting "off" time.

8.4.7.5 Timer off/on. The machine will turn off automatically when reaching the setting "off" time, and then turn on automatically when reaching the setting "on" time.

8.4.7.6 The timer function will not change the AC current operation mode. Suppose AC is off now, it will not start up firstly after setting the "timer off" function. And when reaching the

setting time, the timer LED will be off and the AC running mode has not been changed.

8.4.7.7 The setting time is relative time.

8.4.8 Sleep function mode

8.4.8.1 Operation time in sleep mode is 7 hours. After 7 hours the AC quits this mode and turns off.

8.4.8.2. Operation process in sleep mode is as follow:

When cooling, the setting temperature rises 1°C(33.8°F) (be lower than 30°C(86°F)) every one hour, 2 hours later the setting temperature stops rising and indoor fan is fixed as low speed.

When heating, the setting temperature decreases 1°C(33.8°F) (be higher than 17°C(62.6°F)) every one hour, 2 hours later the setting temperature stops rising and indoor fan is fixed as low speed. (Anti-cold wind function has the priority)

8.4.8.3 Timer setting is available

8.4.8.4 When user uses timer off function in sleep mode (or sleep function in timer off mode), if the timing is less than 7 hours, sleep function will be cancelled when reaching the setting time. If the timing is more than 7 hours, the machine will not stop until reaches the setting time in sleep mode.

8.4.9 Auto-Restart function

The indoor unit is equipped with auto-restart function, which is carried out through an auto-restart module. In case of a sudden power failure, the module memorizes the setting conditions before the power failure. The unit will resume the previous operation setting (not including swing function) automatically after 3 minutes when power returns.

If the memorization condition is forced cooling mode, the unit will run in cooling mode for 30 minutes and turn to auto mode as 24°C(75.2°F) setting temp.

If AC is off before power off and AC is required to start up now, the compressor will have 1 minute delay when power on. Other conditions, the compressor will have 3 minutes delay when restarts.

8.4.10 Follow me

1) If the indoor PCB receives the signal which results from pressing the FOLLOW ME button on remote controller, the buzzer will emit a sound and this indicates the follow me function is initiated. But when the indoor PCB receives signal which sent from remote controller every 3 minutes, the buzzer will not respond. When the unit is running with follow me function, the PCB will control the unit according to the temperature from follow me signal, and the temperature collection function of room temperature sensor will be shielded, but the error detective function of room temperature sensor will be still valid.

2) When the follow me function is available, the PCB will control the unit according to the room temperature from the remote controller and the setting temperature.

3) The PCB will take action to the mode change information from remote controller signal, but it will not be affected by the setting temperature.

4) When the unit is running with follow me function, if the PCB doesn't receive any signal from remote controller for 7 minutes or pressing FOLLOW ME button again, the follow me function will be turned off automatically, and the temperature will control the unit according to the room temperature detected from its own room temperature sensor and setting temperature.

8.4.11 Self clean

For heat pump models which are provided with this function, after running in cooling or drying mode, if the user press "Self Clean" button on remote controller, firstly, indoor unit runs in fan only mode for a while, then low heat operation and finally runs in fan only again. This function can keep the inside of indoor unit dry and prevent breeding of mold.

8.4.12 Refrigerant Leakage Detection

With this new technology, the display area will show "EC" when the outdoor unit detects refrigerant leakage.

8.4.13 Louver Position Memory Function

When starting the unit again after shutting down, its louver will restore to the angle originally set by the user, but the precondition is that the angle must be within the allowable range, if it exceeds, it will memorize the maximum angle of the louver. During operation, if the power fails or the end user shuts down the unit in the turbo mode, the louver will restore to the default angle.

8.4.14 8°C Heating(optional)

In heating operation, the preset temperature of the air conditioner can be as lower as 8°C,

which keeps the room temperature steady at 8°C and prevents household things freezing when the house is unoccupied for a long time in severe cold weather.

8.4.15 Silence operation(optional)

Press the “silence” button on remote controller to initiate SILENCE function. When the Silence function is activated, the compressor running frequency will keep lower than F2 and the indoor unit will bring faint breeze, which will reduce the noise to the lowest level and create a quiet and comfortable room for you.

9. Troubleshooting

Safety

Electricity power is still kept in capacitors even the power supply is shut off. Do not forget to discharge the electricity power in capacitor.

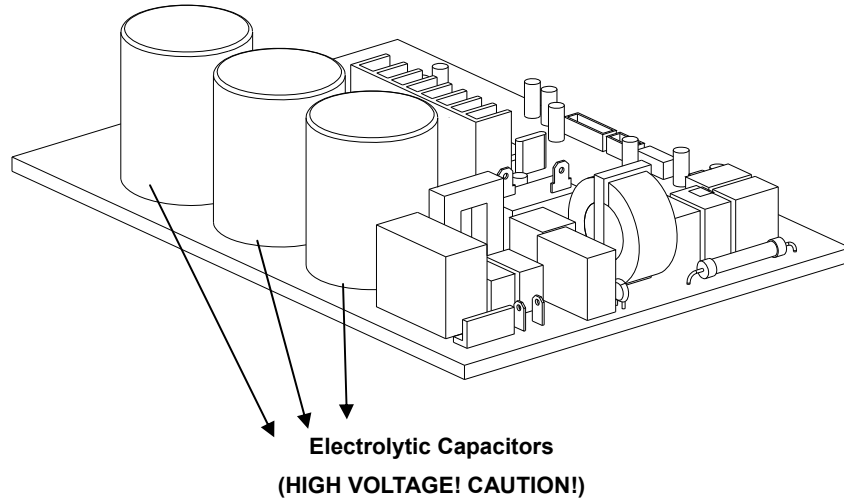

For other models, please connect discharge resistance (approx. 100Ω 40W) or soldering iron (plug) between +, - terminals of the electrolytic capacitor on the contrary side of the outdoor PCB.

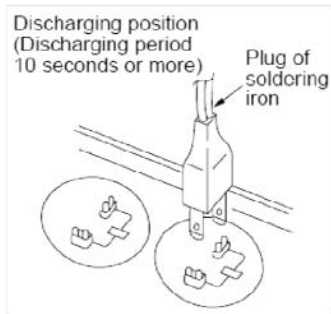

Note: The picture above is only for reference. The plug of your side may be different.

9.1 Indoor Unit Error Display

Operation lamp	Timer lamp	Display	LED STATUS
☆ 1 time	X	E0	Indoor unit EEPROM parameter error
☆ 2 times	X	E1	Indoor / outdoor units communication error
☆ 3 times	X	E2	Zero-crossing signal detection error
☆ 4 times	X	E3	Indoor fan speed has been out of control
☆ 5 times	X	E4	Indoor room temperature sensor T1 open circuit or short circuit
☆ 6 times	X	E5	Evaporator coil temperature sensor T2 open circuit or short circuit
☆ 7 times	X	EC	Refrigerant leakage detection
☆ 2 times	O	F1	Outdoor ambient temperature sensor T4 open circuit or short circuit
☆ 3 times	O	F2	Condenser coil temperature sensor T3 open circuit or short circuit
☆ 4 times	O	F3	Compressor discharge temperature sensor T5 open circuit or short circuit
☆ 5 times	O	F4	Outdoor unit EEPROM parameter error
☆ 6 times	O	F5	Outdoor fan speed has been out of control
☆ 1 times	☆	P0	IPM malfunction or IGBT over-strong current protection
☆ 2 times	☆	P1	Over voltage or over low voltage protection
☆ 3 times	☆	P2	High temperature protection of compressor top diagnosis and solution(only for 9k,12k models)
☆ 5 times	☆	P4	Inverter compressor drive error

O (light) X (off) ☆ (flash)

9.2 Outdoor unit error display

➤ YN09GMFI22RPD AND YN012GMFI22RPD

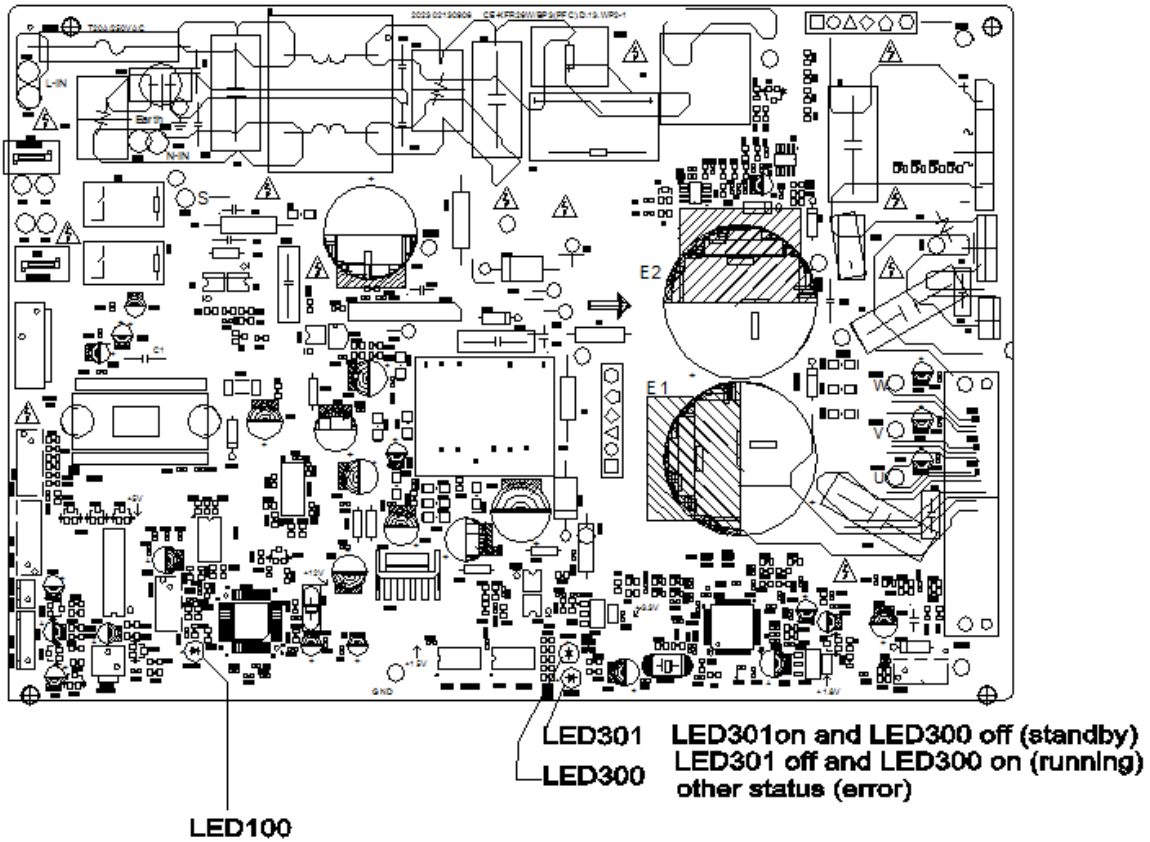

After power on, LED100(Blue color) will be slow flash(0.2Hz) when the unit is in standby and quick flash (2.5Hz) if the unit has some problems.

No.	Problems	LED301 (Green)	LED300 (Red)	IU display
1	standby for normal	O	X	
2	Operation normally	X	O	
3	IPM malfunction or IGBT over-strong current protection	☆	X	P0
4	Over voltage or too low voltage protection	O	O	P1
5	Over voltage or too low voltage protection	O	☆	P1
6	Inverter compressor drive error	X	☆	P4
7	Inverter compressor drive error	☆	O	P4
8	Inverter compressor drive error	☆	☆	P4

O (light) X (off) ☆ (2.5Hz flash)

➤ **YN018GMFI22RPD**

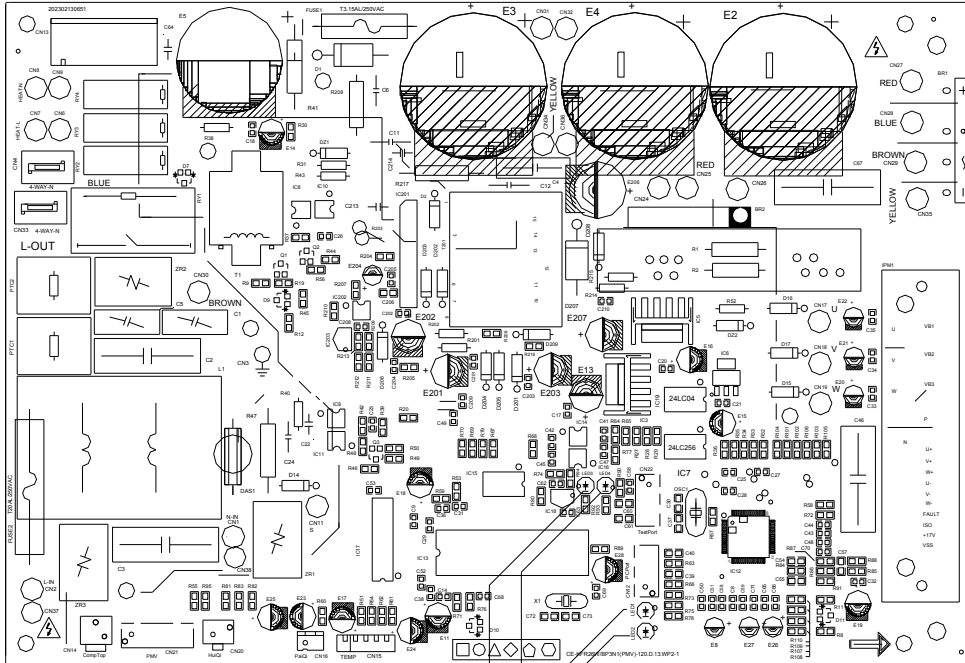

- LED2 LED2 on and LED1 off (standby)
- LED1 LED2 off and LED1 on (running)
- other status (error)
- LED4 power light
- when power is on, LED4 always on
- LED3 Flashing once per second (low speed flashing) (standby)
- Flashing once per half second (high speed flashing) (error)
- always on (running)

No.	Problems	LED2 (Green)	LED1 (Red)	IU display
1	standby for normal	O	X	
2	Operation normally	X	O	
3	IPM malfunction or IGBT over-strong current protection	☆	X	P0
4	Over voltage or too low voltage protection	O	O	P1
5	Over voltage or too low voltage protection	O	☆	P1
6	Inverter compressor drive error	X	☆	P4
7	Inverter compressor drive error	☆	O	P4
8	Inverter compressor drive error	☆	☆	P4

O (light) X (off) ☆ (2.5Hz flash)

➤ **YN024GMFI22RPD**

LED1

(standby) Flashing once per second (low speed flashing)

(error) Flashing once per half second (high speed flashing)

(running) aways on

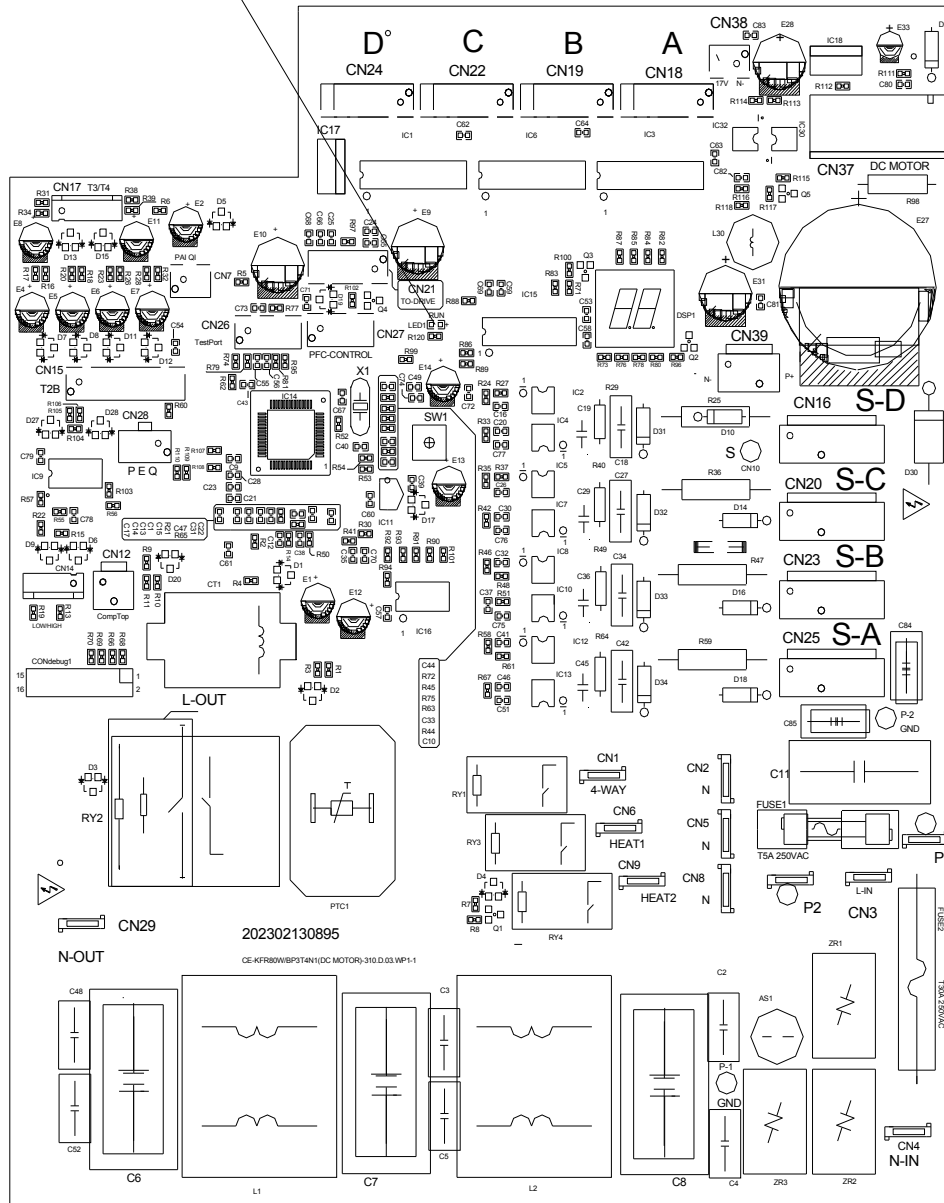

9.3 Diagnosis and Solution

9.3.1 EEPROM parameter error diagnosis and solution(E0/F4)

Error Code	E0/F4
Malfunction decision conditions	Indoor or outdoor PCB main chip does not receive feedback from EEPROM chip.
Supposed causes	<ul style="list-style-type: none"> ● Installation mistake ● PCB faulty

Trouble shooting:

Shut off the power supply and turn it on 5 seconds later. Is it still displaying the error code ?

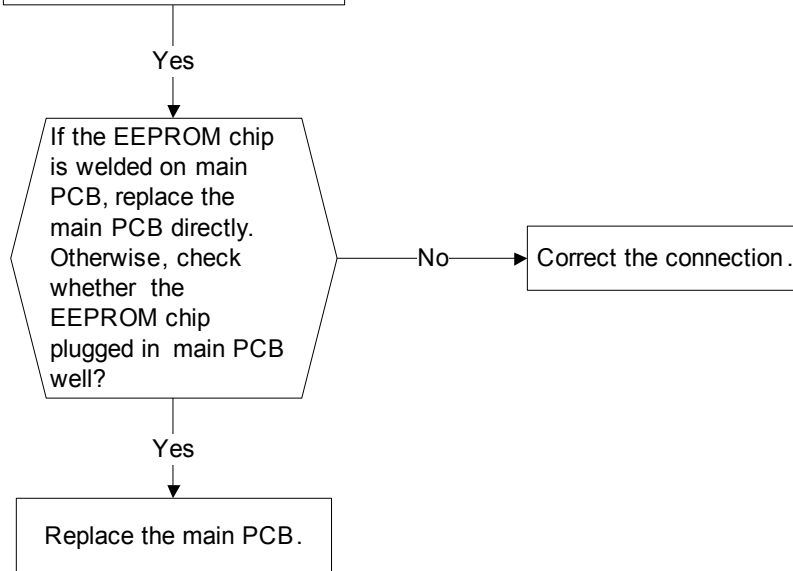

EEPROM: a read-only memory whose contents can be erased and reprogrammed using a pulsed voltage. For the location of EEPROM chip, please refer to the below photos.



[]

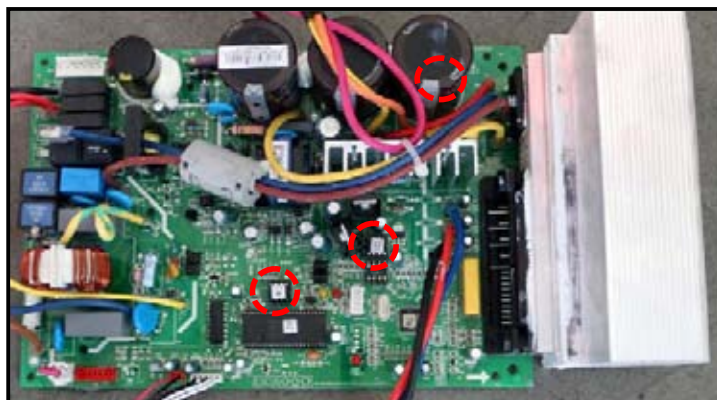

[]

[]

9.3.2 Indoor / outdoor unit's communication diagnosis and solution(E1)

Error Code	E1
Malfunction decision conditions	Indoor unit does not receive the feedback from outdoor unit during 110 seconds and this condition happens four times continuously.
Supposed causes	<ul style="list-style-type: none"> Wiring mistake Indoor or outdoor PCB faulty

Trouble shooting:

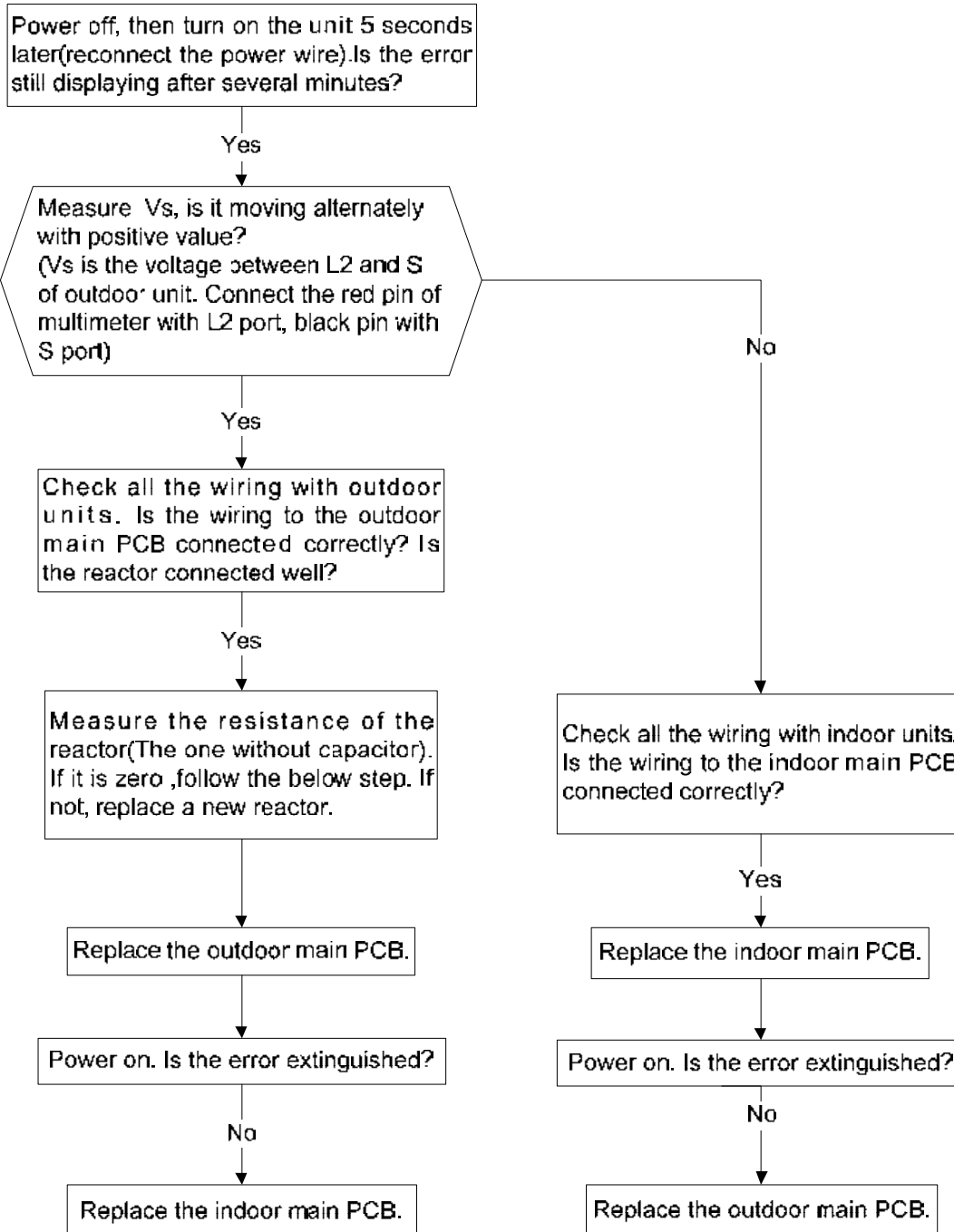



Remark:

Use a multimeter to test the DC voltage between L2 port and S port of outdoor unit. The red pin of multimeter connects with L2 port while the black pin is for S port. (Set Multimeter to measure DC Volts)

When AC is normal running, the voltage will move alternately between -50V to 50V.

If the outdoor unit has malfunction, the voltage will move alternately with positive value.

While if the indoor unit has malfunction, the voltage will be a certain value.



Remark:

Use a multimeter to test the resistance of the reactor which does not connect with capacitor.

The normal value should be around zero ohm. Otherwise, the reactor must have malfunction and need to be replaced.

9.3.3 Zero crossing detection error diagnosis and solution(E2)

Error Code	E2
Malfunction decision conditions	When PCB does not receive zero crossing signal feedback for 4 minutes or the zero crossing signal time interval is abnormal.
Supposed causes	<ul style="list-style-type: none">● Connection mistake● PCB faulty

Trouble shooting:

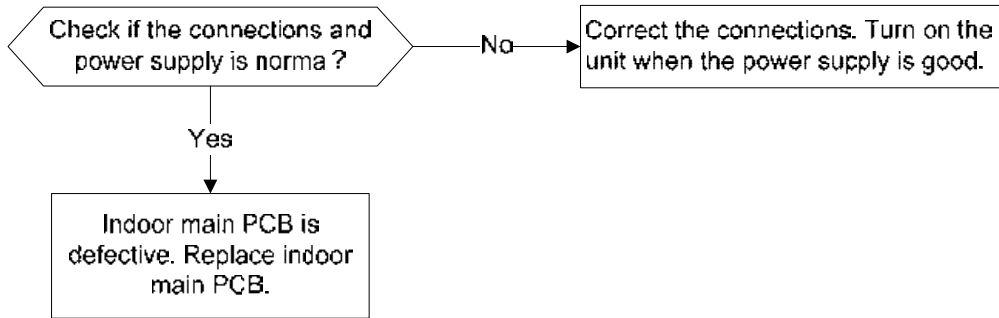

9.3.4 Fan speed has been out of control diagnosis and solution(E3)

Error Code	E3
Malfunction decision conditions	When indoor fan speed keeps too low (300RPM) for certain time, the unit will stop and the LED will display the failure.
Supposed causes	<ul style="list-style-type: none"> ● Wiring mistake ● Fan ass'y faulty ● Fan motor faulty ● PCB faulty

Trouble shooting:

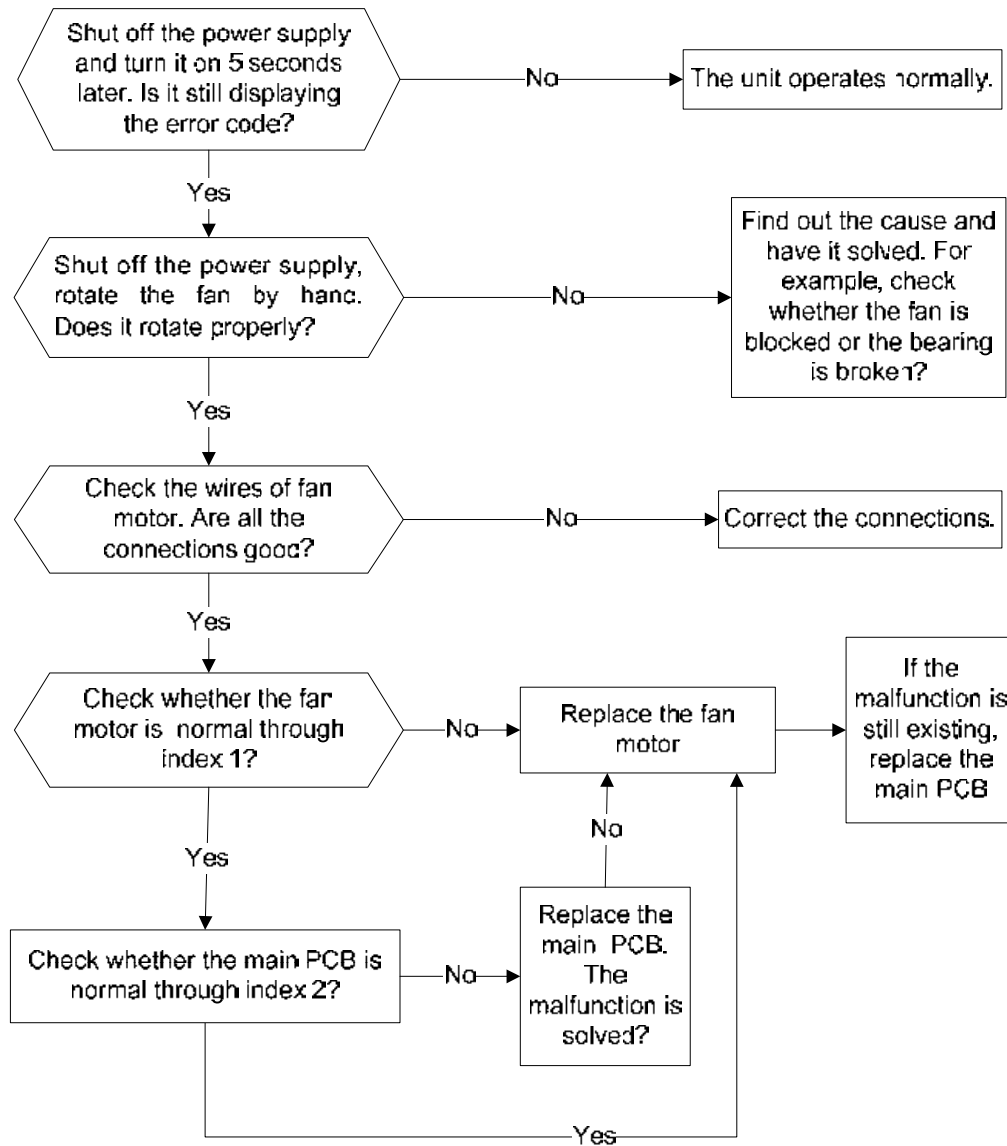

Index 1:

1. Indoor or Outdoor DC Fan Motor (control chip is in fan motor)

Measure the resistance value of each winding by using the tester. If any resistance value is zero, the fan motor must have problems and need to be replaced.

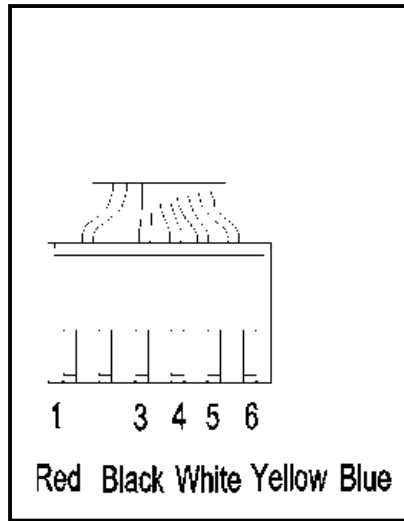

Index 2:

1: Indoor or Outdoor DC Fan Motor (control chip is in fan motor)

Power on and when the unit is in standby, measure the voltage of pin 1-pin 3, pin 4-pin 3 in fan motor connector. If the value of the voltage is not in the range showing in below table, the PCB must have problems and need to be replaced.

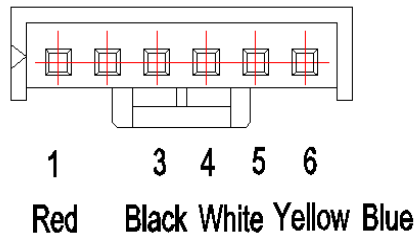

DC motor voltage input and output

NO.	Color	Signal	Voltage
1	Red	Vs/Vm	280V~380V
2	---	---	---
3	Black	GND	0V
4	White	Vcc	14-17.5V
5	Yellow	Vsp	0~5.6V
6	Blue	FG	14-17.5V

2.Outdoor DC Fan Motor(control chip is in outdoor PCB)

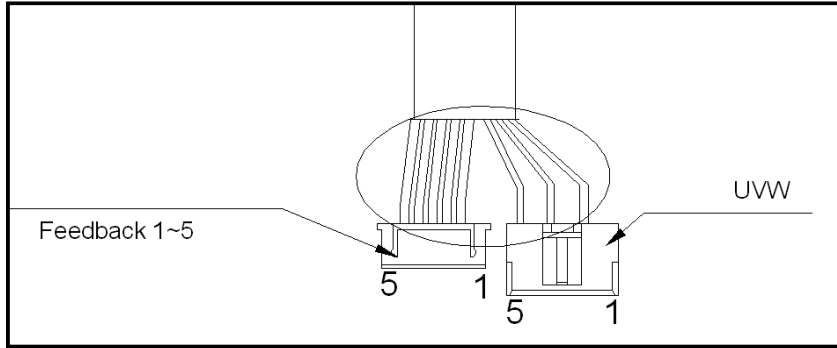

NO.	1	2	3	4	5
Color	Orange	Grey	White	Pink	Black
Signal	Hu	Hv	Hw	Vcc	GND

Color	Red	Blue	Yellow
Signal	W	V	U

- 1) Release the UVW connector. Measure the resistance of U-V, U-W, V-W. If the resistance is not equal to each other, the fan motor must have problems and need to be replaced. Otherwise, go to step 2.
- 2) Power on and when the unit is in standby, measure the voltage of pin4-5 in feedback signal connector. If the value is not 5V, change the PCB. Otherwise, go to step 3.
- 3) Rotate the fan by hand, measure the voltage of pin1-5, pin 2-5 and pin 3-5 in feedback signal connector. If any voltage is not positive voltage fluctuation, the fan motor must have problems and need to be replaced.

9.3.5 Open circuit or short circuit of temperature sensor diagnosis and solution(E5)

Error Code	E5
Malfunction decision conditions	If the sampling voltage is lower than 0.06V or higher than 4.94V, the LED will display the failure.
Supposed causes	<ul style="list-style-type: none">● Wiring mistake● Sensor faulty

Trouble shooting:

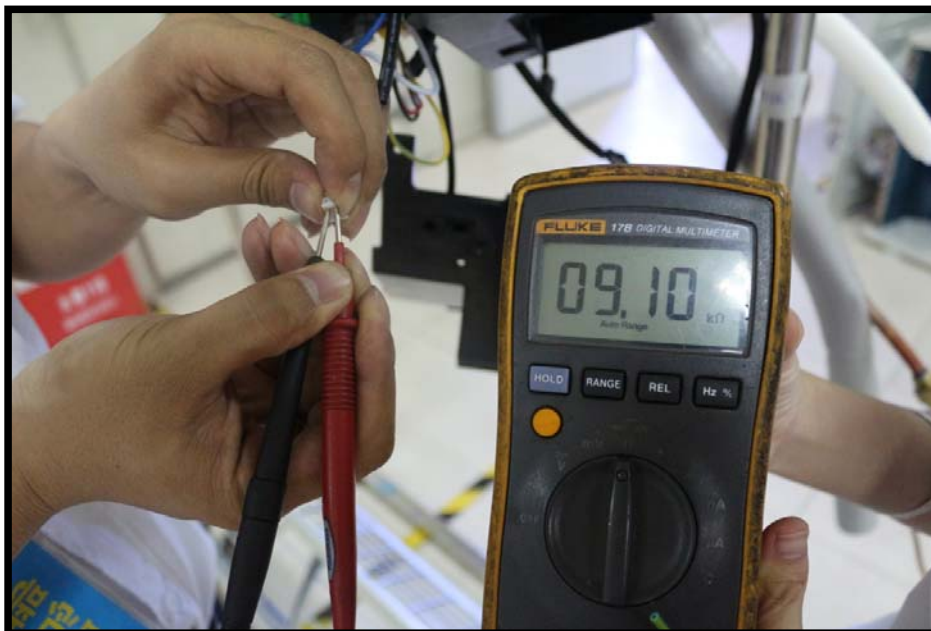
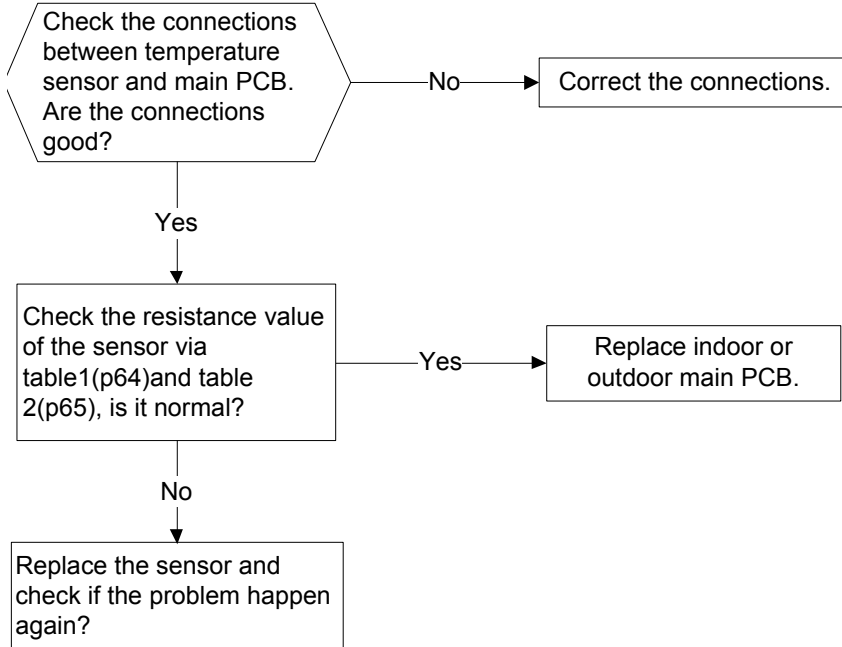

9.3.6 Refrigerant Leakage Detection diagnosis and solution(EC)

Error Code	EC
Malfunction decision conditions	<p>Define the evaporator coil temp.T2 of the compressor just starts running as Tcool.</p> <p>In the beginning 5 minutes after the compressor starts up, if $T2 < T_{cool} - 2^{\circ}\text{C}$ ($T_{cool} - 35.6^{\circ}\text{F}$) does not keep continuous 4 seconds and this situation happens 3 times, the display area will show "EC" and AC will turn off.</p>
Supposed causes	<ul style="list-style-type: none"> ● T2 sensor faulty ● Indoor PCB faulty ● System problems, such as leakage or blocking.

Trouble shooting:

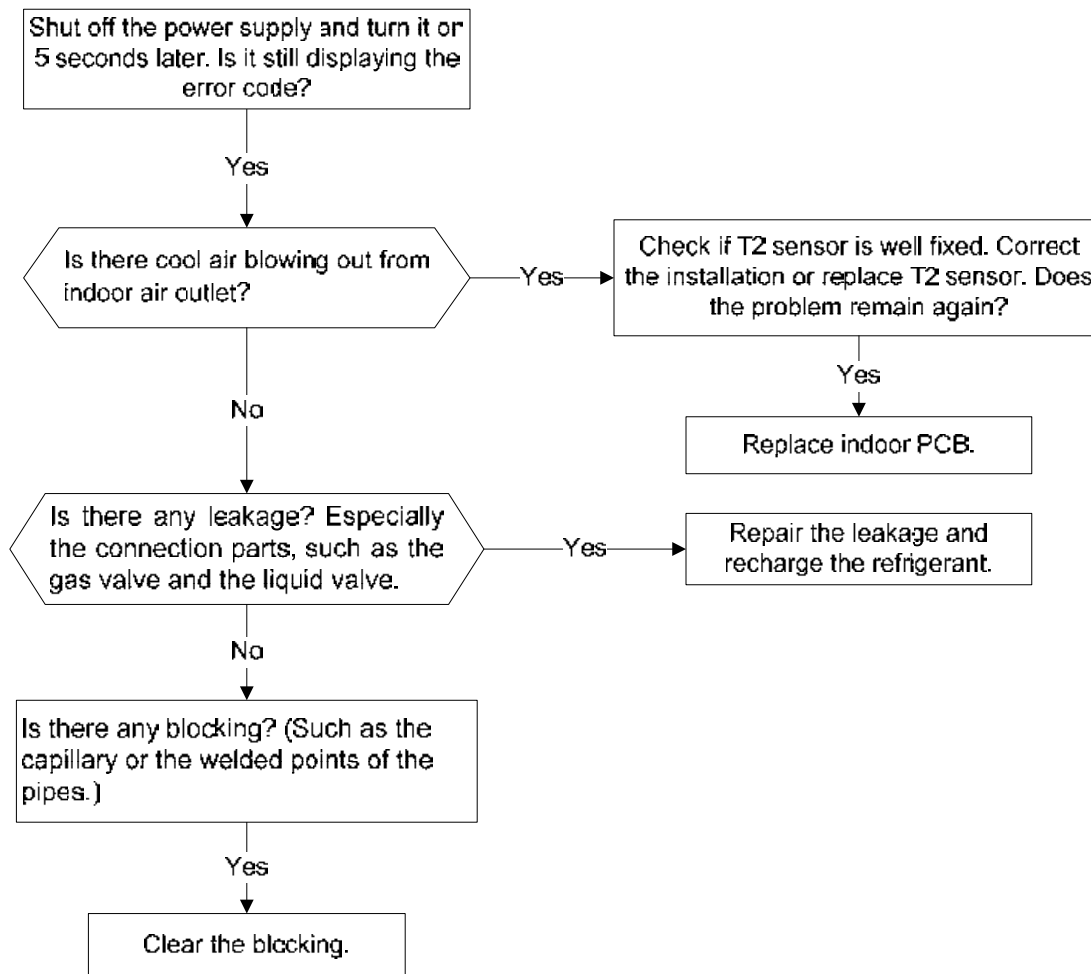

9.3.7 IPM malfunction or IGBT over-strong current protection diagnosis and solution(P0)

Error Code	P0
Malfunction decision conditions	When the voltage signal that IPM send to compressor drive chip is abnormal, the display LED will show “P0” and AC will turn off.
Supposed causes	<ul style="list-style-type: none"> ● Wiring mistake ● IPM malfunction ● Outdoor fan ass’y faulty ● Compressor malfunction ● Outdoor PCB faulty

Trouble shooting:

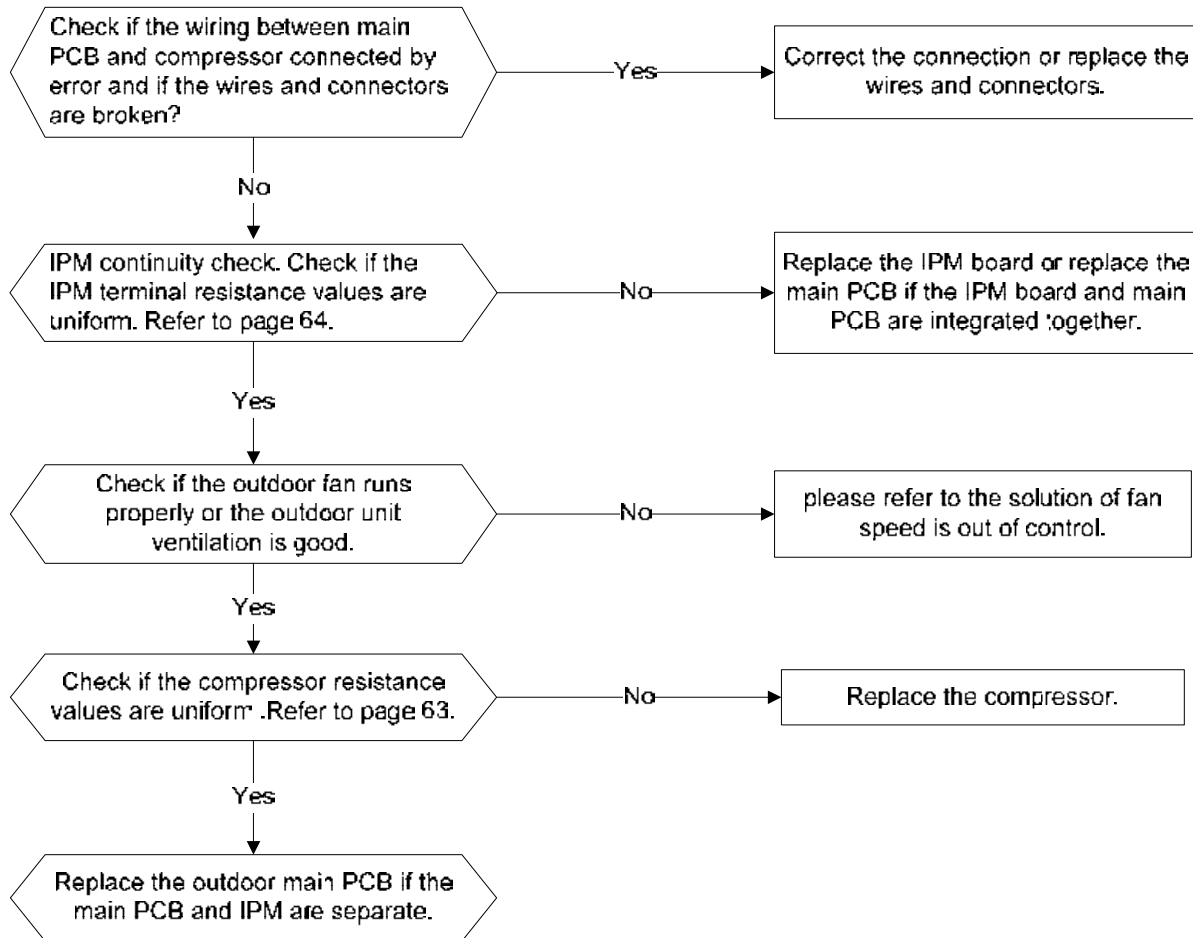

Take the 9k model as example:

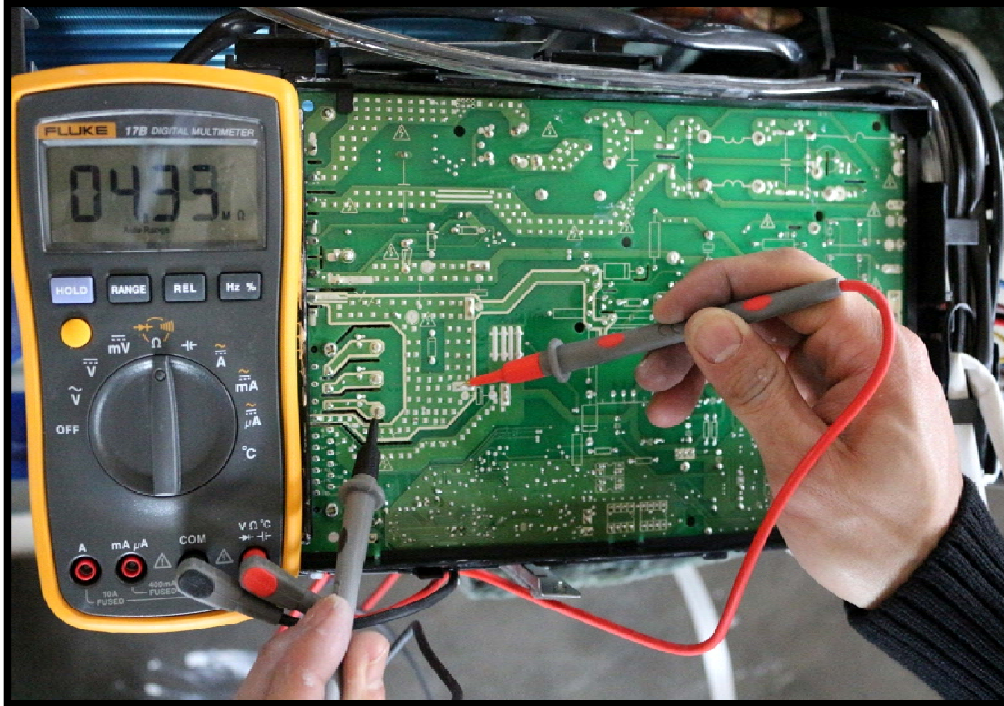

P-U

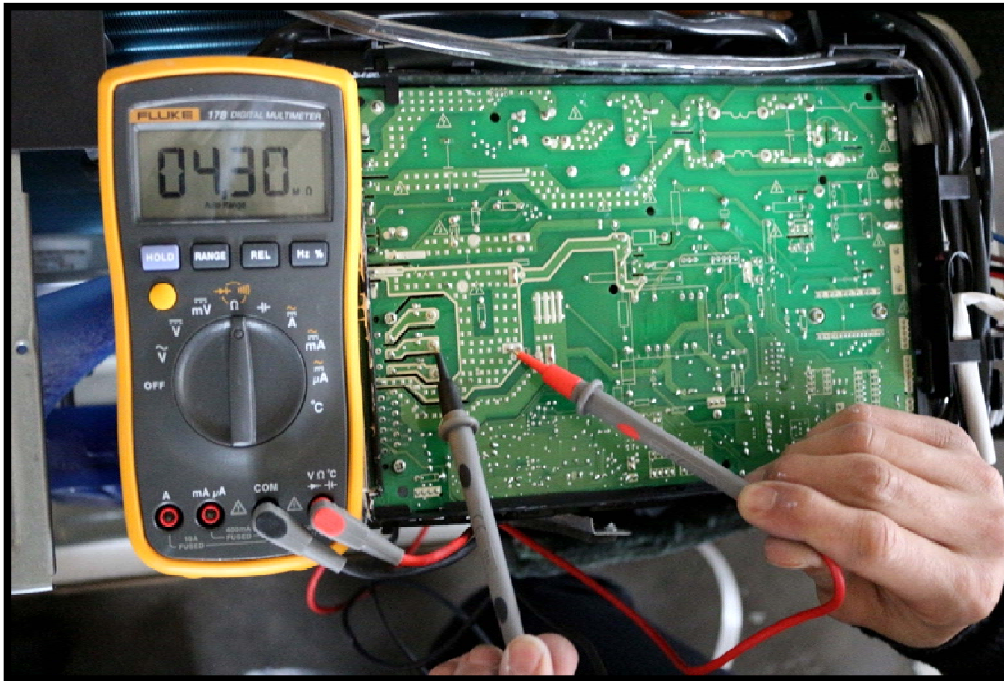

P-V

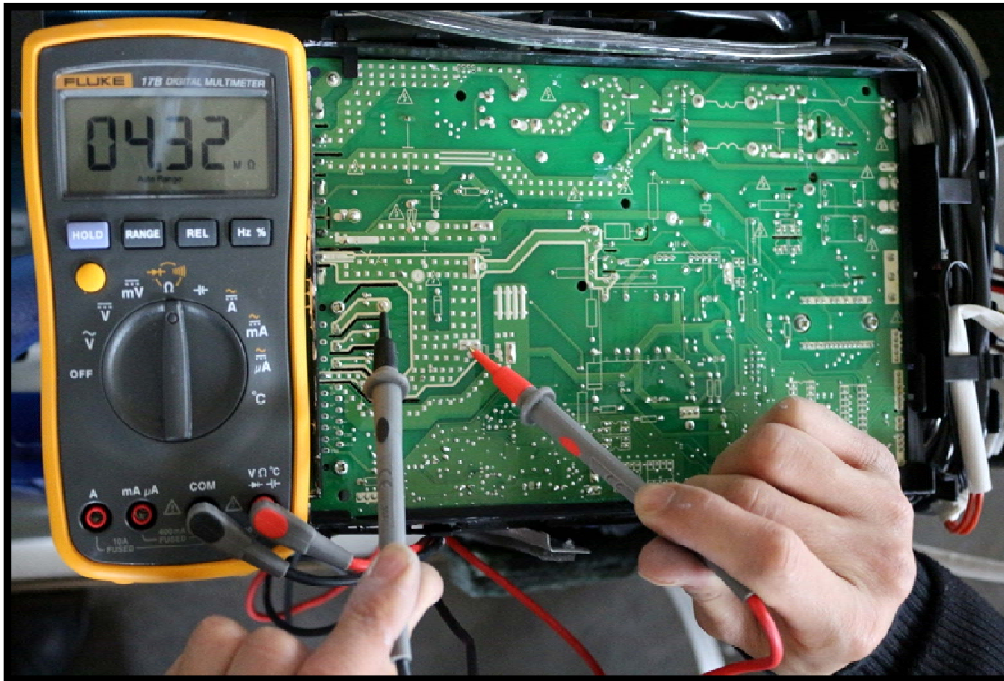

P-W

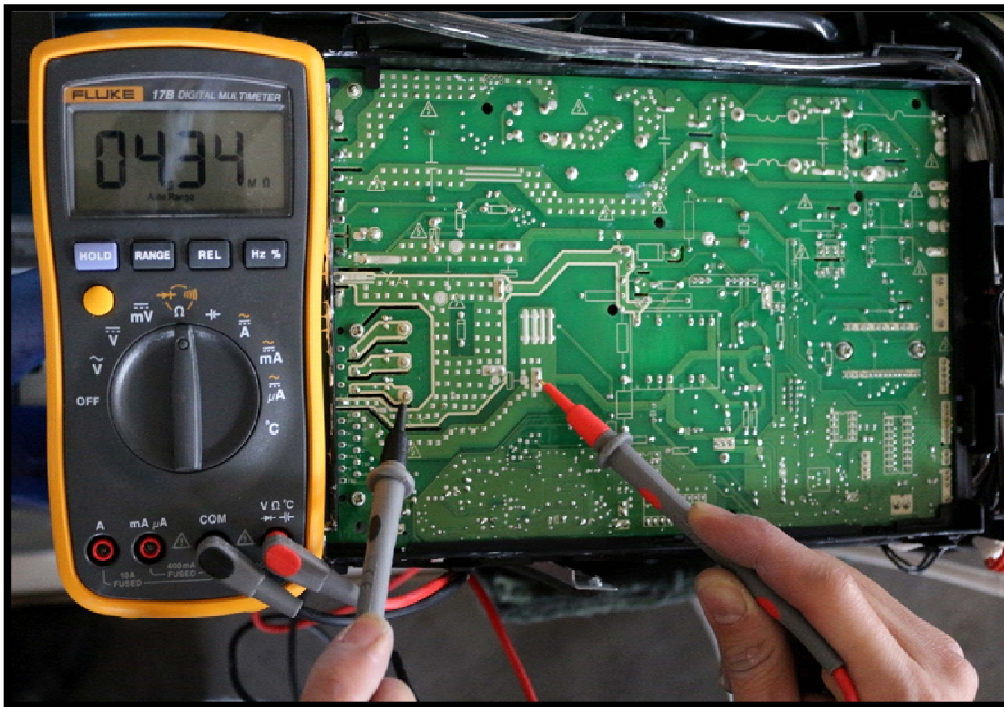

N-U

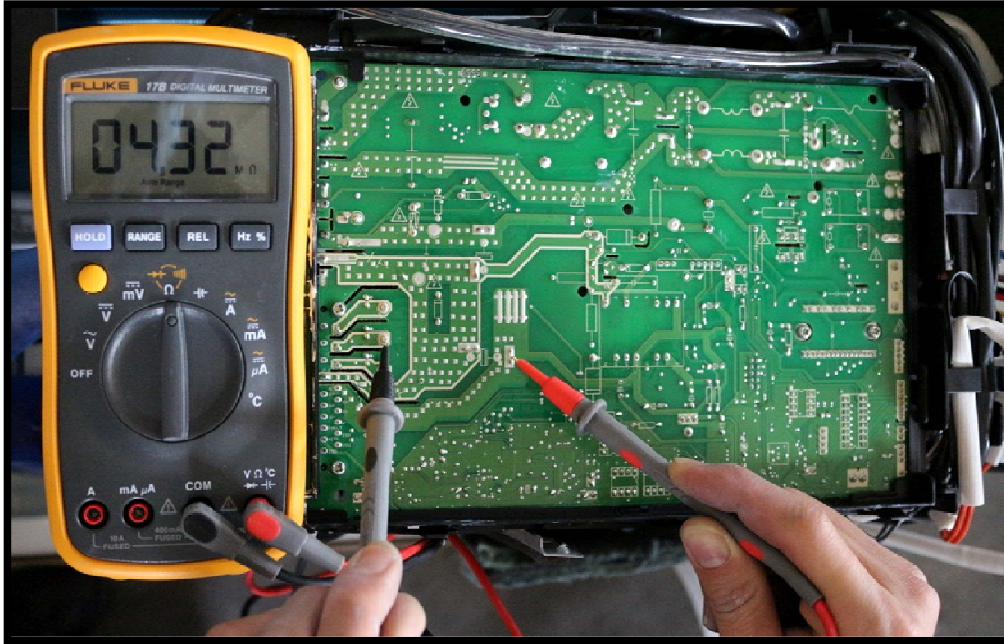

N-V

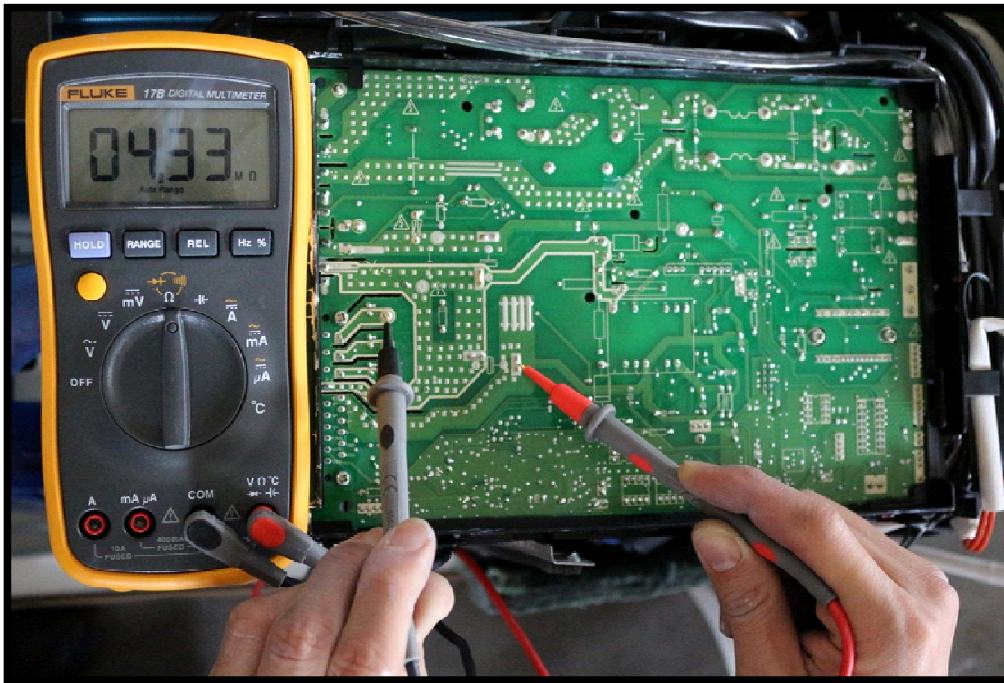

N-W

9.3.8 Over voltage or too low voltage protection diagnosis and solution(P1)

Error Code	P1
Malfunction decision conditions	An abnormal voltage rise or drop is detected by checking the specified voltage detection circuit.
Supposed causes	<ul style="list-style-type: none"> ● Power supply problems. ● System leakage or block ● PCB faulty

Trouble shooting:

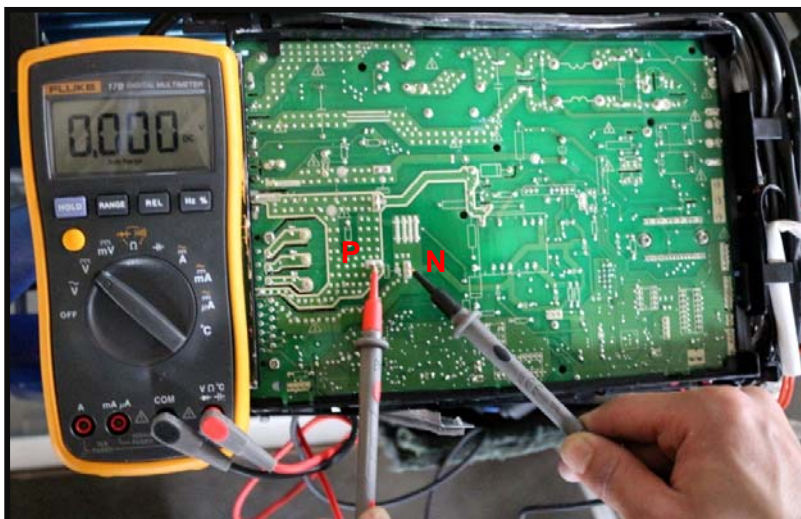
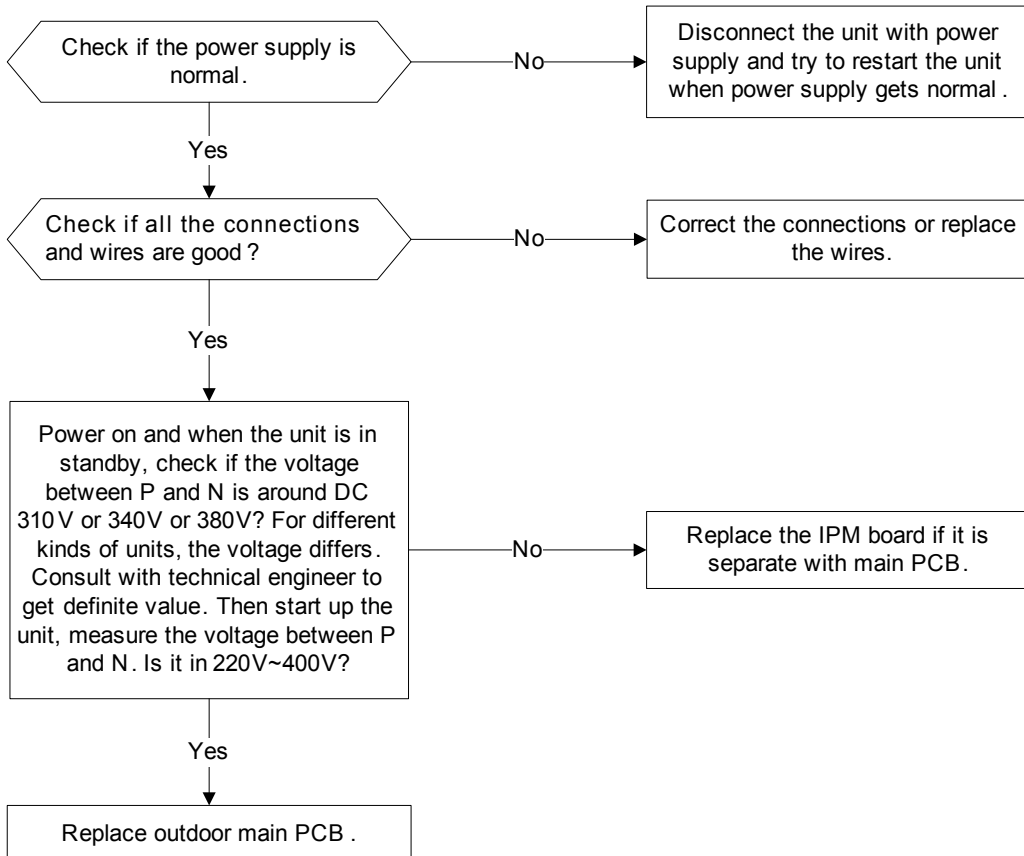

9.3.9 High temperature protection of compressor top diagnosis and solution(P2)

Error Code	P2
Malfunction decision conditions	If the sampling voltage is not 5V, the LED will display the failure.
Supposed causes	<ul style="list-style-type: none"> ● Power supply problems. ● System leakage or block ● PCB faulty

Trouble shooting:

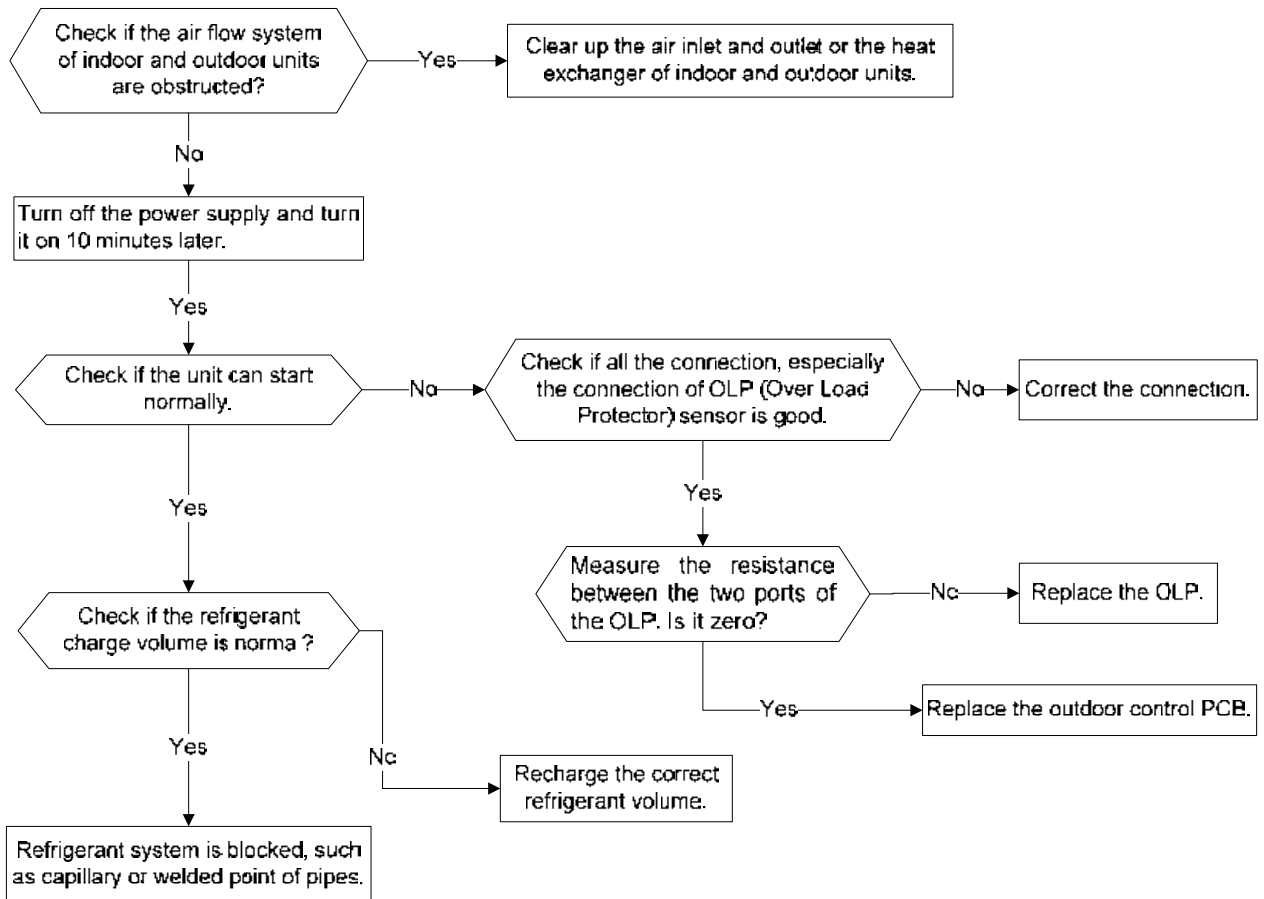

9.3.10 Inverter compressor drive error diagnosis and solution(P4)

Error Code	P4
Malfunction decision conditions	An abnormal inverter compressor drive is detected by a special detection circuit, including communication signal detection, voltage detection, compressor rotation speed signal detection and so on.
Supposed causes	<ul style="list-style-type: none"> ● Wiring mistake ● IPM malfunction ● Outdoor fan ass'y faulty ● Compressor malfunction ● Outdoor PCB faulty

Trouble shooting:

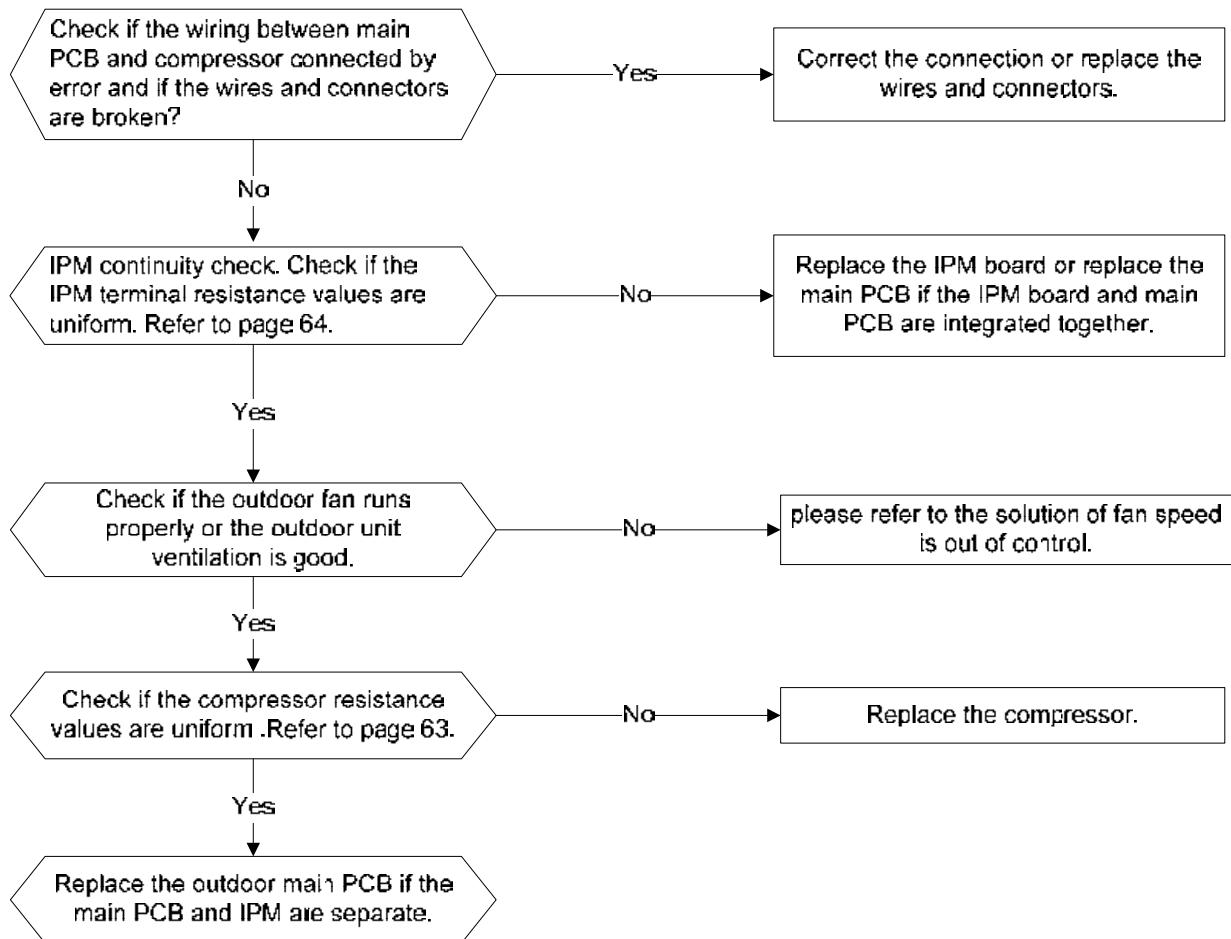

Main parts check

1. Temperature sensor checking

Disconnect the temperature sensor from PCB, measure the resistance value with a tester.

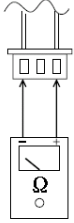

Tester

Temperature sensors.

Room temp.(T1) sensor,

Indoor coil temp.(T2) sensor,

Outdoor coil temp.(T3) sensor,

Outdoor ambient temp.(T4) sensor,

Compressor discharge temp.(T5) sensor.

Measure the resistance value of each winding by using the multi-meter.

Appendix 1 Temperature Sensor Resistance Value Table for T1,T2,T3,T4 (°C--K)

°C	°F	K Ohm	°C	°F	K Ohm	°C	°F	K Ohm	°C	°F	K Ohm
-20	-4	115.266	20	68	12.6431	60	140	2.35774	100	212	0.62973
-19	-2	108.146	21	70	12.0561	61	142	2.27249	101	214	0.61148
-18	0	101.517	22	72	11.5	62	144	2.19073	102	216	0.59386
-17	1	96.3423	23	73	10.9731	63	145	2.11241	103	217	0.57683
-16	3	89.5865	24	75	10.4736	64	147	2.03732	104	219	0.56038
-15	5	84.219	25	77	10	65	149	1.96532	105	221	0.54448
-14	7	79.311	26	79	9.55074	66	151	1.89627	106	223	0.52912
-13	9	74.536	27	81	9.12445	67	153	1.83003	107	225	0.51426
-12	10	70.1698	28	82	8.71983	68	154	1.76647	108	226	0.49989
-11	12	66.0898	29	84	8.33566	69	156	1.70547	109	228	0.486
-10	14	62.2756	30	86	7.97078	70	158	1.64691	110	230	0.47256
-9	16	58.7079	31	88	7.62411	71	160	1.59068	111	232	0.45957
-8	18	56.3694	32	90	7.29464	72	162	1.53668	112	234	0.44699
-7	19	52.2438	33	91	6.98142	73	163	1.48481	113	235	0.43482
-6	21	49.3161	34	93	6.68355	74	165	1.43498	114	237	0.42304
-5	23	46.5725	35	95	6.40021	75	167	1.38703	115	239	0.41164
-4	25	44	36	97	6.13059	76	169	1.34105	116	241	0.4006
-3	27	41.5878	37	99	5.87359	77	171	1.29078	117	243	0.38991
-2	28	39.8239	38	100	5.62961	78	172	1.25423	118	244	0.37956
-1	30	37.1988	39	102	5.39689	79	174	1.2133	119	246	0.36954
0	32	35.2024	40	104	5.17519	80	176	1.17393	120	248	0.35982
1	34	33.3269	41	106	4.96392	81	178	1.13604	121	250	0.35042
2	36	31.5635	42	108	4.76253	82	180	1.09958	122	252	0.3413
3	37	29.9058	43	109	4.5705	83	181	1.06448	123	253	0.33246
4	39	28.3459	44	111	4.38736	84	183	1.03069	124	255	0.3239
5	41	26.8778	45	113	4.21263	85	185	0.99815	125	257	0.31559
6	43	25.4954	46	115	4.04589	86	187	0.96681	126	259	0.30754
7	45	24.1932	47	117	3.88673	87	189	0.93662	127	261	0.29974
8	46	22.5662	48	118	3.73476	88	190	0.90753	128	262	0.29216
9	48	21.8094	49	120	3.58962	89	192	0.8795	129	264	0.28482
10	50	20.7184	50	122	3.45097	90	194	0.85248	130	266	0.2777
11	52	19.6891	51	124	3.31847	91	196	0.82643	131	268	0.27078
12	54	18.7177	52	126	3.19183	92	198	0.80132	132	270	0.26408
13	55	17.8005	53	127	3.07075	93	199	0.77709	133	271	0.25757
14	57	16.9341	54	129	2.95896	94	201	0.75373	134	273	0.25125
15	59	16.1156	55	131	2.84421	95	203	0.73119	135	275	0.24512
16	61	15.3418	56	133	2.73823	96	205	0.70944	136	277	0.23916
17	63	14.6181	57	135	2.63682	97	207	0.68844	137	279	0.23338
18	64	13.918	58	136	2.53973	98	208	0.66818	138	280	0.22776
19	66	13.2631	59	138	2.44677	99	210	0.64862	139	282	0.22231

Appendix 2 Temperature Sensor Resistance Value Table for T5 (°C --K)

°C	°F	K Ohm	°C	°F	K Ohm	°C	°F	K Ohm	°C	°F	K Ohm
-20	-4	542.7	20	68	68.66	60	140	13.59	100	212	3.702
-19	-2	511.9	21	70	65.62	61	142	13.11	101	214	3.595
-18	0	483	22	72	62.73	62	144	12.65	102	216	3.492
-17	1	455.9	23	73	59.98	63	145	12.21	103	217	3.392
-16	3	430.5	24	75	57.37	64	147	11.79	104	219	3.296
-15	5	406.7	25	77	54.89	65	149	11.38	105	221	3.203
-14	7	384.3	26	79	52.53	66	151	10.99	106	223	3.113
-13	9	363.3	27	81	50.28	67	153	10.61	107	225	3.025
-12	10	343.6	28	82	48.14	68	154	10.25	108	226	2.941
-11	12	325.1	29	84	46.11	69	156	9.902	109	228	2.86
-10	14	307.7	30	86	44.17	70	158	9.569	110	230	2.781
-9	16	291.3	31	88	42.33	71	160	9.248	111	232	2.704
-8	18	275.9	32	90	40.57	72	162	8.94	112	234	2.63
-7	19	261.4	33	91	38.89	73	163	8.643	113	235	2.559
-6	21	247.8	34	93	37.3	74	165	8.358	114	237	2.489
-5	23	234.9	35	95	35.78	75	167	8.084	115	239	2.422
-4	25	222.8	36	97	34.32	76	169	7.82	116	241	2.357
-3	27	211.4	37	99	32.94	77	171	7.566	117	243	2.294
-2	28	200.7	38	100	31.62	78	172	7.321	118	244	2.233
-1	30	190.5	39	102	30.36	79	174	7.086	119	246	2.174
0	32	180.9	40	104	29.15	80	176	6.859	120	248	2.117
1	34	171.9	41	106	28	81	178	6.641	121	250	2.061
2	36	163.3	42	108	26.9	82	180	6.43	122	252	2.007
3	37	155.2	43	109	25.86	83	181	6.228	123	253	1.955
4	39	147.6	44	111	24.85	84	183	6.033	124	255	1.905
5	41	140.4	45	113	23.89	85	185	5.844	125	257	1.856
6	43	133.5	46	115	22.89	86	187	5.663	126	259	1.808
7	45	127.1	47	117	22.1	87	189	5.488	127	261	1.762
8	46	121	48	118	21.26	88	190	5.32	128	262	1.717
9	48	115.2	49	120	20.46	89	192	5.157	129	264	1.674
10	50	109.8	50	122	19.69	90	194	5	130	266	1.632
11	52	104.6	51	124	18.96	91	196	4.849			
12	54	99.69	52	126	18.26	92	198	4.703			
13	55	95.05	53	127	17.58	93	199	4.562			
14	57	90.66	54	129	16.94	94	201	4.426			
15	59	86.49	55	131	16.32	95	203	4.294			
16	61	82.54	56	133	15.73	96	205	4.167			
17	63	78.79	57	135	15.16	97	207	4.045			
18	64	75.24	58	136	14.62	98	208	3.927			
19	66	71.86	59	138	14.09	99	210	3.812			

Appendix 3:

$$\Delta T(^{\circ}\text{F}) = \frac{9\Delta T(^{\circ}\text{C})}{5}$$

$^{\circ}\text{C}$	$^{\circ}\text{F}$	$^{\circ}\text{C}$	$^{\circ}\text{F}$	$^{\circ}\text{C}$	$^{\circ}\text{F}$	$^{\circ}\text{C}$	$^{\circ}\text{F}$	$^{\circ}\text{C}$	$^{\circ}\text{F}$
-5	23	21	69.8	51	123.8	82	179.6	113	235.4
-4	24.8	22	71.6	52	125.6	83	181.4	114	237.2
-3	26.6	23	73.4	53	127.4	84	183.2	115	239
-2	28.4	24	75.2	54	129.2	85	185	116	240.8
-1	30.2	25	77	55	131	86	186.8	117	242.6
0	32	25.5	77.9	56	132.8	87	188.6	118	244.4
0.5	32.9	26	78.8	57	134.6	88	190.4	119	246.2
1	33.8	27	80.6	58	136.4	89	192.2	120	248
1.5	34.7	28	82.4	59	138.2	90	194	121	249.8
2	35.6	29	84.2	60	140	91	195.8	122	251.6
2.5	36.5	30	86	61	141.8	92	197.6	123	253.4
3	37.4	31	87.8	62	143.6	93	199.4	124	255.2
3.5	38.3	32	89.6	63	145.4	94	201.2	125	257
4	39.2	33	91.4	64	147.2	95	203	126	258.8
4.5	40.1	34	93.2	65	149	96	204.8	127	260.6
5	41	35	95	66	150.8	97	206.6	128	262.4
6	42.8	36	96.8	67	152.6	98	208.4	129	264.2
7	44.6	37	98.6	68	154.4	99	210.2	130	266
8	46.4	38	100.4	69	156.2	100	212	131	267.8
9	48.2	39	102.2	70	158	101	213.8	132	269.6
10	50	40	104	71	159.8	102	215.6	133	271.4
11	51.8	41	105.8	72	161.6	103	217.4	134	273.2
12	53.6	42	107.6	73	163.4	104	219.2	135	275
13	55.4	43	109.4	74	165.2	105	221	136	276.8
14	57.2	44	111.2	75	167	106	222.8	137	278.6
15	59	45	113	76	168.8	107	224.6	138	280.4
16	60.8	46	114.8	77	170.6	108	226.4	139	282.2
17	62.6	47	116.6	78	172.4	109	228.2	140	284
18	64.4	48	118.4	79	174.2	110	230	141	285.8
19	66.2	49	120.2	80	176	111	231.8	142	287.6
20	68	50	122	81	177.8	112	233.6	143	289.4

2.Compressor checking

Measure the resistance value of each winding by using the tester.

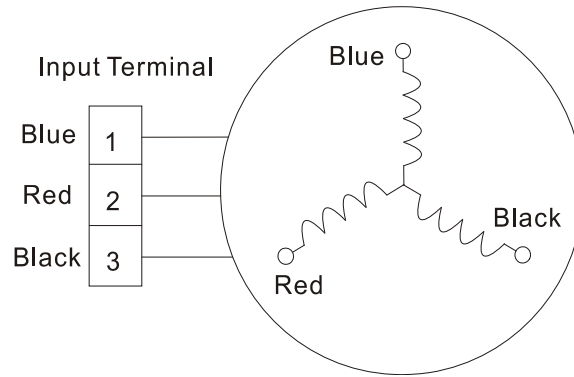

Position	Resistance Value		
	DA110S1C-30FZ	DA130M1C-31FZ	DA250S2C-30MT
Blue - Red	0.8Ω	1.77Ω	0.55Ω
Blue - Black	(20°C /68°F)	(20°C /68°F)	(20°C /68°F)
Red - Blue			



3. IPM continuity check

Turn off the power, let the large capacity electrolytic capacitors discharge completely, and dismount the IPM. Use a digital tester to measure the resistance between P and UVWN; UVW and N.

Digital tester		Normal resistance value	Digital tester		Normal resistance value
(+)Red	(-)Black		(+)Red	(-)Black	
P	N	∞ (Several MΩ)	U	N	∞ (Several MΩ)
	U		V		
	V		W		
	W		(+)Red		

4: Indoor AC Fan Motor

Measure the resistance value of each winding by using the tester.

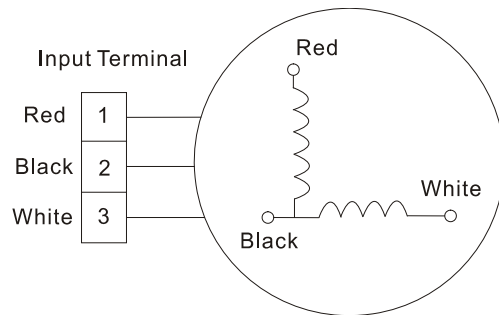

Position	Resistance Value	
	RPG13B	
Black - Red	100.5Ω±8% (20°C /68°F) (Brand: Weiling)	100Ω±8% (20°C /68°F) (Brand: Dayang)
White - Black	64.5Ω±8% (20°C /68°F) (Brand: Weiling)	68.5Ω±8% (20°C /68°F) (Brand: Dayang)

5: Pressure On Service Port

Cooling chart:

°F(°C)	ODT	75	85	95	105	115
	IDT	(23.89)	(29.44)	(35)	(40.56)	(46.11)
BAR	70/59	8.2	7.8	8.1	8.6	10.1
BAR	75/63	8.6	8.3	8.7	9.1	10.7
BAR	80/67	9.3	8.9	9.1	9.6	11.2

°F(°C)	ODT	75	85	95	105	115
	IDT	(23.89)	(29.44)	(35)	(40.56)	(46.11)
PSI	70/59	119	113	117	125	147
PSI	75/63	124	120	126	132	155
PSI	80/67	135	129	132	140	162

°F(°C)	ODT	75	85	95	105	115
	IDT	(23.89)	(29.44)	(35)	(40.56)	(46.11)
MPA	70/59	0.82	0.78	0.81	0.86	1.01
MPA	75/63	0.86	0.83	0.87	0.91	1.07
MPA	80/67	0.93	0.89	0.91	0.96	1.12

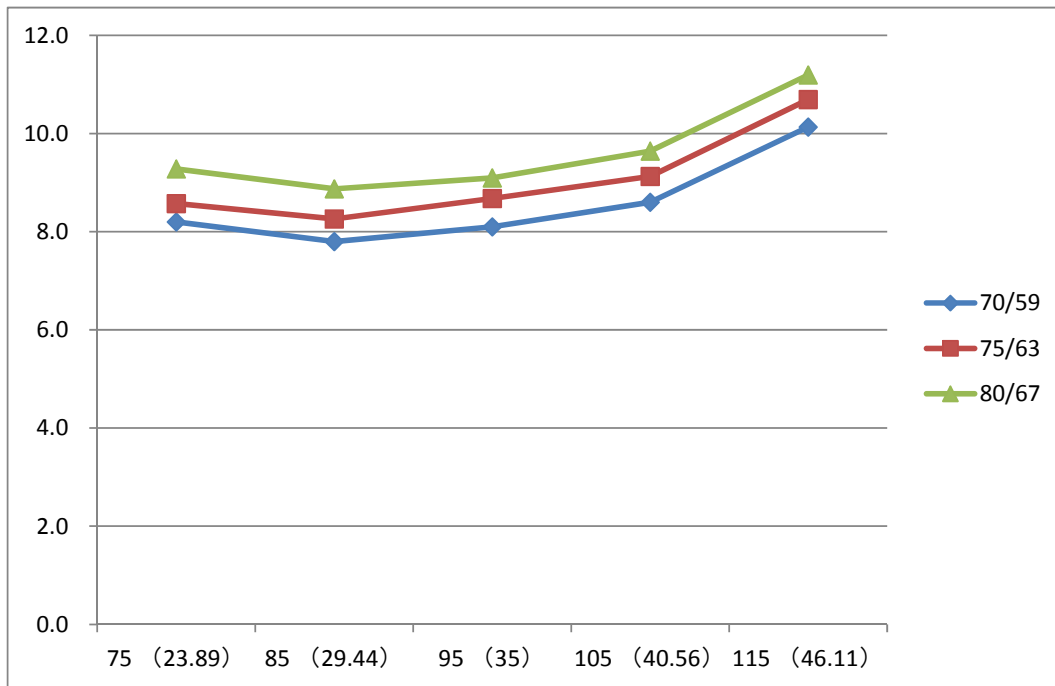

Heating Chart:

°F (°C)	ODT		57/53	47/43	37/33	27/23	17/13
	IDT		(13.89/11.67)	(8.33/6.11)	(2.78/0.56)	(-2.78/-5)	(-8.33/-10.56)
BAR	55		30.3	28.5	25.3	22.8	20.8
BAR	65		32.5	30.0	26.6	25.4	23.3
BAR	75		33.8	31.5	27.8	26.3	24.9

°F (°C)	ODT		57/53	47/43	37/33	27/23	17/13
	IDT		(13.89/11.67)	(8.33/6.11)	(2.78/0.56)	(-2.78/-5)	(-8.33/-10.56)
PSI	55		439	413	367	330	302
PSI	65		471	435	386	368	339
PSI	75		489	457	403	381	362

°F (°C)	ODT		57/53	47/43	37/33	27/23	17/13
	IDT		(13.89/11.67)	(8.33/6.11)	(2.78/0.56)	(-2.78/-5)	(-8.33/-10.56)
MPA	55		3.03	2.85	2.53	2.28	2.08
MPA	65		3.25	3.00	2.66	2.54	2.33
MPA	75		3.38	3.15	2.78	2.63	2.49

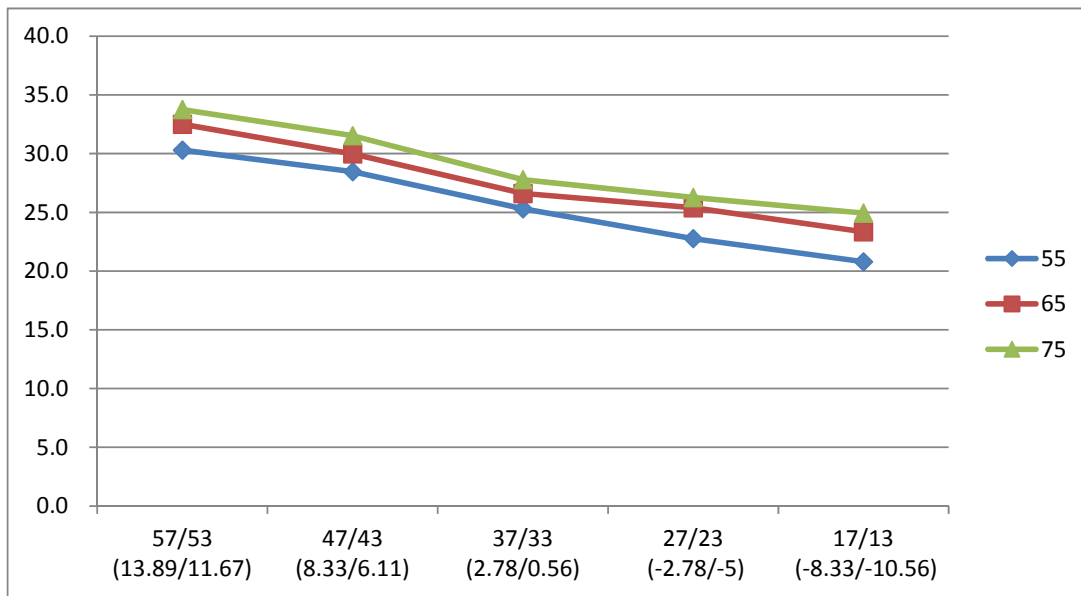

10 Disassembly Instructions

Note: This part is for reference, the photos may have slight difference with your machine.

10.1 Indoor unit

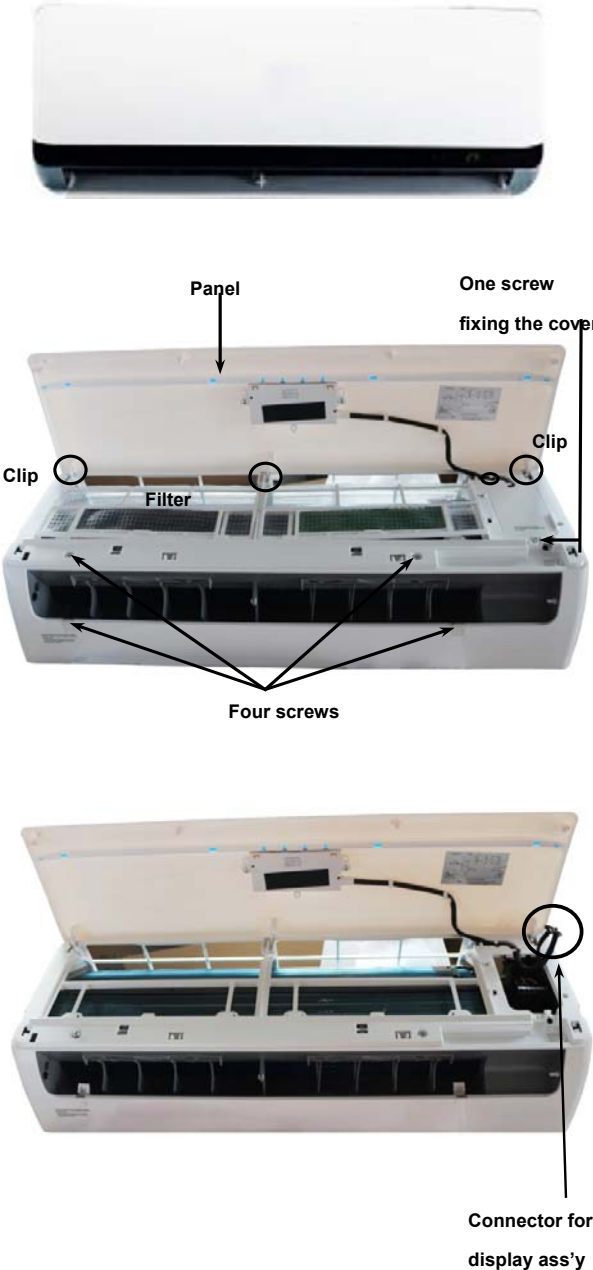
No.	Parts name	Procedures	Remarks
1	Front panel	<p>How to remove the front panel.</p> <ol style="list-style-type: none"> 1) Pull the below side of the panel and release the clips. Then remove the front panel. 2) Remove the filter and horizontal louver. 3) Remove the four fixing screws. 4) Remove the cover (one screw). 5) Lift the panel frame and release the connector of display ass'y. connectors. Then remove the panel frame assembly. 	<p>Overview:</p> 

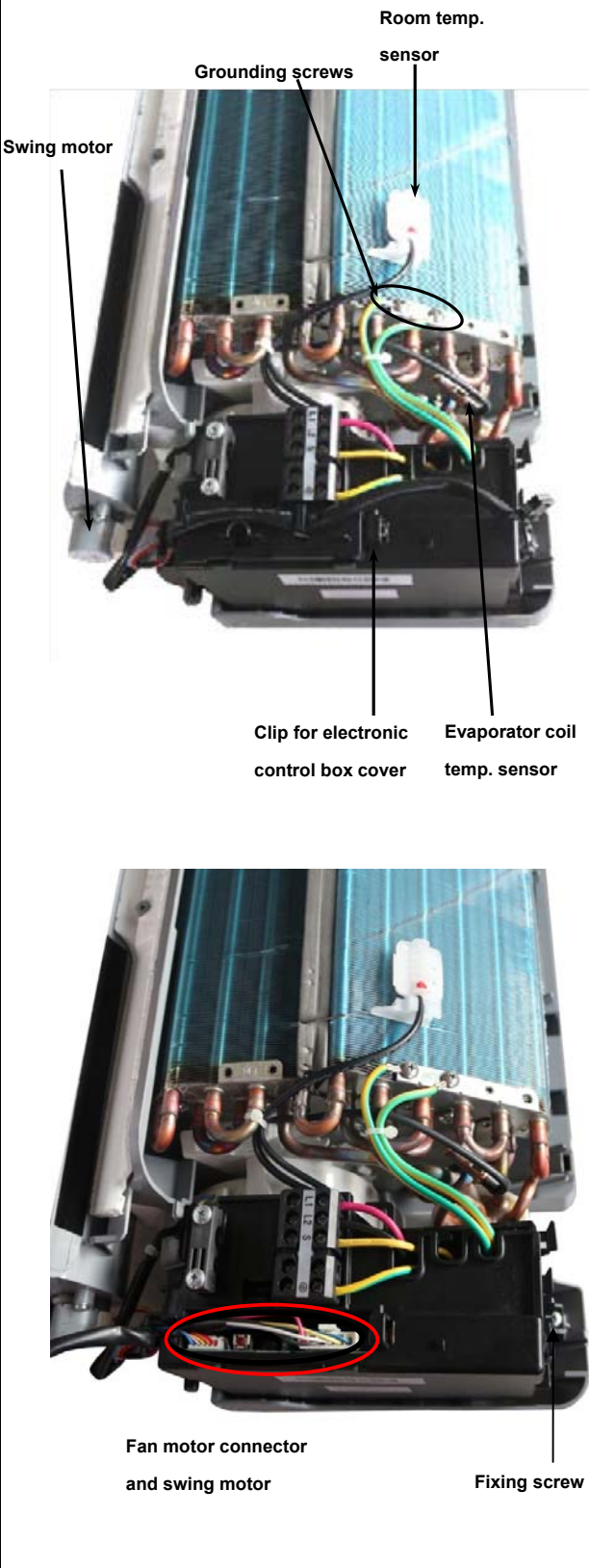
<p>2</p>	<p>Electrical parts</p>	<p>How to remove the electrical parts.</p> <p>1) After remove the front panel from procedure 1, pull out the room temp. sensor and evaporator coil sensor. Remove the grounding screws.</p> <p>2) Pull out the clip toward the left side and open the cover.</p> <p>3) Remove the fixing screw and open the electrical box cover.</p> <p>4) Pull out the connectors of the swing motor and fan motor .</p> <p>5) Remove the fixing screw and then remove the electronic control box and air outlet ass'y.</p>	 <p>Room temp. sensor</p> <p>Grounding screws</p> <p>Swing motor</p> <p>Clip for electronic control box cover</p> <p>Evaporator coil temp. sensor</p> <p>Fan motor connector and swing motor</p> <p>Fixing screw</p>
----------	-------------------------	---	---

3

Evaporator

How to remove the evaporator.

1) After remove the front panel ass'y and electrical parts following procedure 1 and procedure 2, remove the pipe holder at the rear side of the unit.

2) Remove the two screws on the evaporator at the base bearing side.



3) Remove two screws on the evaporator at the fixed plates and then lift the evaporator ass'y.

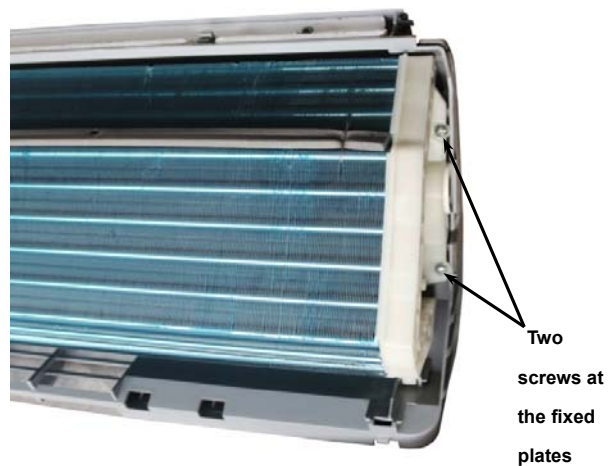

Two screws at the base bearing side





Two screws at the fixed plates

4	Fan and motor	<p>How to remove the fan and motor.</p> <p>1) After remove the evaporator ass'y following procedure 1, procedure 2 and procedure 3, remove the three screws fixing the cover</p> <p>2) Remove the screw fixing the motor and then pull out the motor.</p>	 <p>Three screws</p>  <p>One screw</p>
---	---------------	---	---

10.2 Outdoor unit

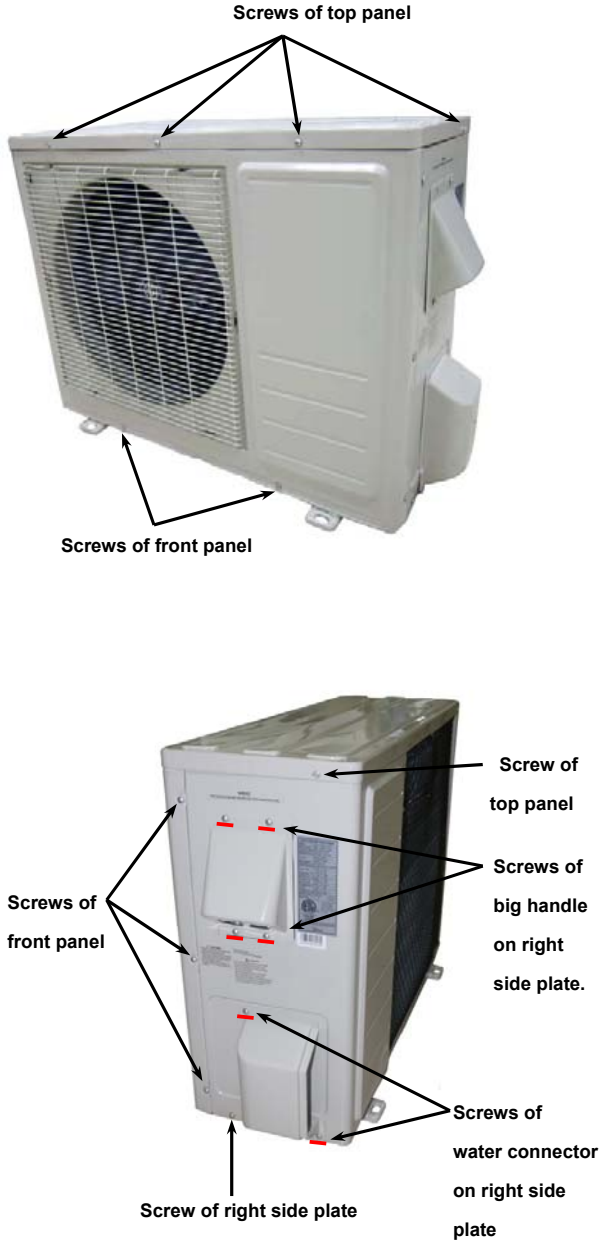
➤ YN009GMFI22RPD and YN012GMFI22RPD

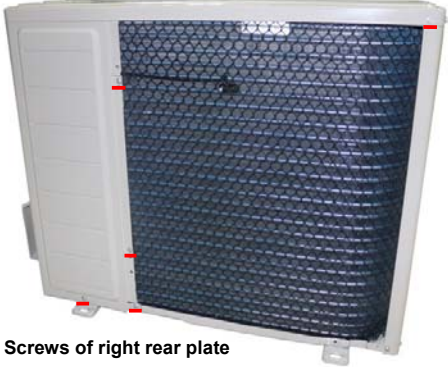
No.	Part name	Procedures	Remarks
1	Panel plate	<p>How to remove the panel plate.</p> <p>1) Stop operation of the air conditioner and turn "OFF" the power breaker.</p> <p>2) Refer to the right side photos, find out the fixing screws of the panels.</p> <p>3) Remove the screws of top panel and remove the top panel.</p>	 <p>The top photograph shows the front-left view of the outdoor unit. Arrows point to the top edge, labeled 'Screws of top panel', and the bottom edge of the front panel, labeled 'Screws of front panel'.</p> <p>The bottom photograph shows the back-right view of the outdoor unit. Arrows point to various screw locations: 'Screw of top panel' at the top edge, 'Screws of front panel' on the left side, 'Screw of right side plate' at the bottom center, 'Screws of big handle on right side plate' on the right side, and 'Screws of water connector on right side plate' at the bottom right.</p>

		<p>4) Remove the screws of the front panel, including the fixing screws of motor holder and then remove the front panel.</p> <p>5) Remove the screws of the right side plate and remove the right side plate.</p>	 <p>Screw of the top panel</p> <p>Screws of right rear plate</p>  <p>Screw of top panel</p> <p>Screws of front panel</p> <p>Screws of the motor holder</p> 
2	Fan ass'y	How to remove the fan	Electronic control box

ass'y.

1) After remove the panel plate following procedure 1, remove the hex nut fixing the fan and then remove the fan.

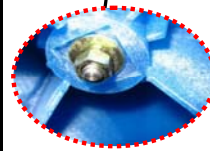
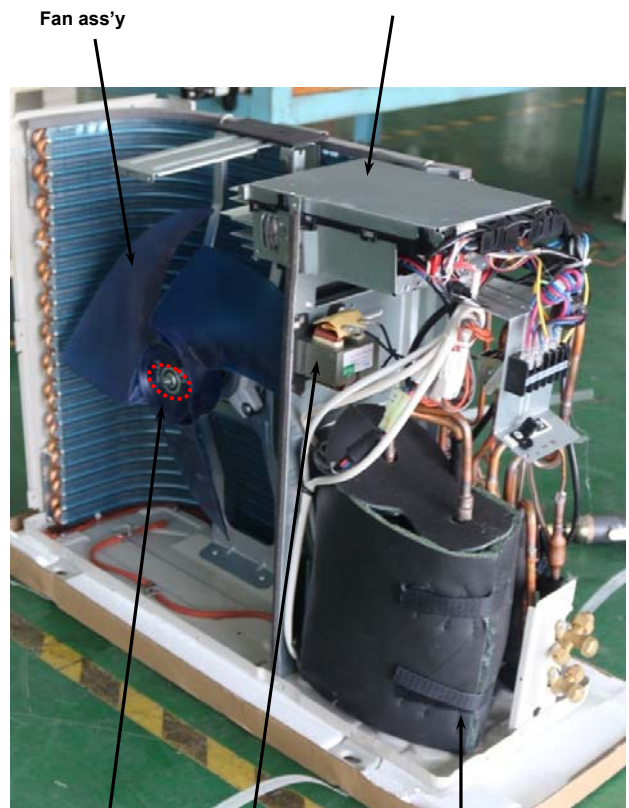





Reactor

Compressor and liquid-gas separator

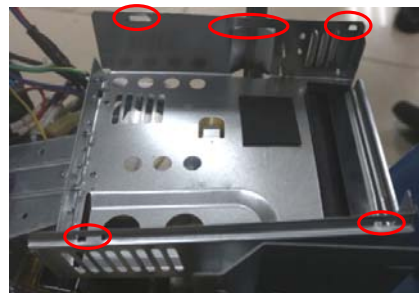
Nut fixing the fan

2) Unfix the hooks and then open the electronic control box cover.



		<p>3) Disconnect the connector for fan motor from the electronic control board.</p> <p>4) Remove the four fixing screws of the fan motor.</p> <p>5) Then remove the fan motor.</p>	<p>Fan motor connector</p>   <p>Four screws</p>
3	Electrical parts	<p>How to remove the electrical parts.</p> <p>1) After finish work of item 1 and item 2, remove the three connectors for the compressor and electrical heaters.</p> <p>2) Release the connector of the reactor.</p>	 <p>Reactor connector</p> <p>Compressor connector and electrical heater connector</p>

3) Pull out the two blue wires connected with the four way valve.

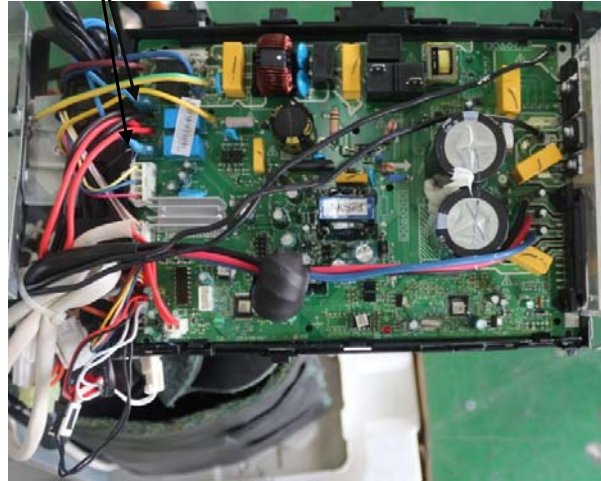

4) Pull out connectors of the compressor top temp. sensor, condenser coil temp. sensor(T3), outdoor ambient temp. sensor(T4) and discharge temp. sensor(T5).

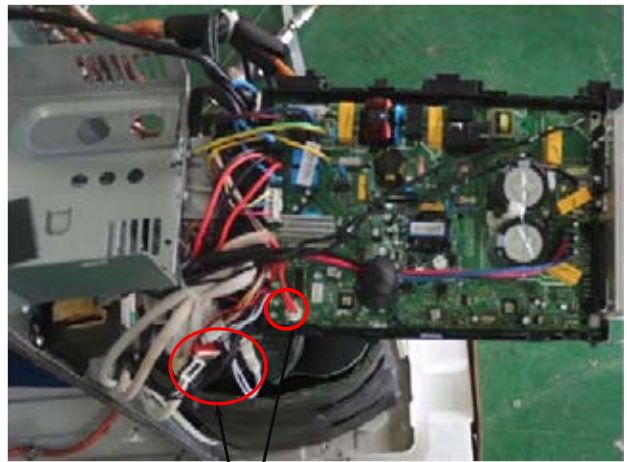

Four connectors of temp. sensors.

5) Remove the ground wires .
6) Remove the power supply wires(L1,L2,S).
7) Then remove the electronic control box.

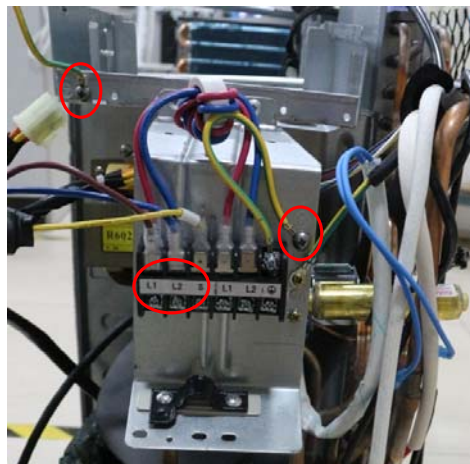

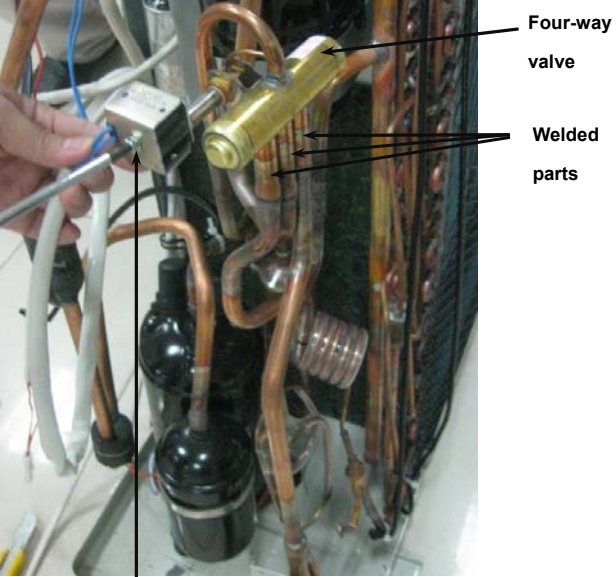
4	Four-way valve	<p>How to remove the four-way valve.</p> <ol style="list-style-type: none"> 1) Perform work of item 1,2,3. 2) Recover refrigerant from the refrigerant circuit. 3) Remove the screw of the coil and then remove the coil. 4) Detach the welded parts of four-way valve and pipe. 5) Then the four-way valve ass'y can be removed 	<p>The picture of four-way valve may be different from the one on your side.</p>  <p>Four-way valve</p> <p>Welded parts</p> <p>Coil of four-way valve, fixing by one screw.</p>
---	----------------	---	---

5	Compressor	<p>How to remove the compressor.</p> <ol style="list-style-type: none"> 1) After perform work of item 1,2,3. 2) Remove the discharge pipe and suction pipe with a burner. 3) Remove the hex nuts and washers fixing the compressor on bottom plate. 4) Lift the compressor from the base pan assembly. 	 <p>Discharge pipe and suction pipe</p> <p>Nuts of compress</p>
---	------------	--	---

➤ YN018GMFI22RPD

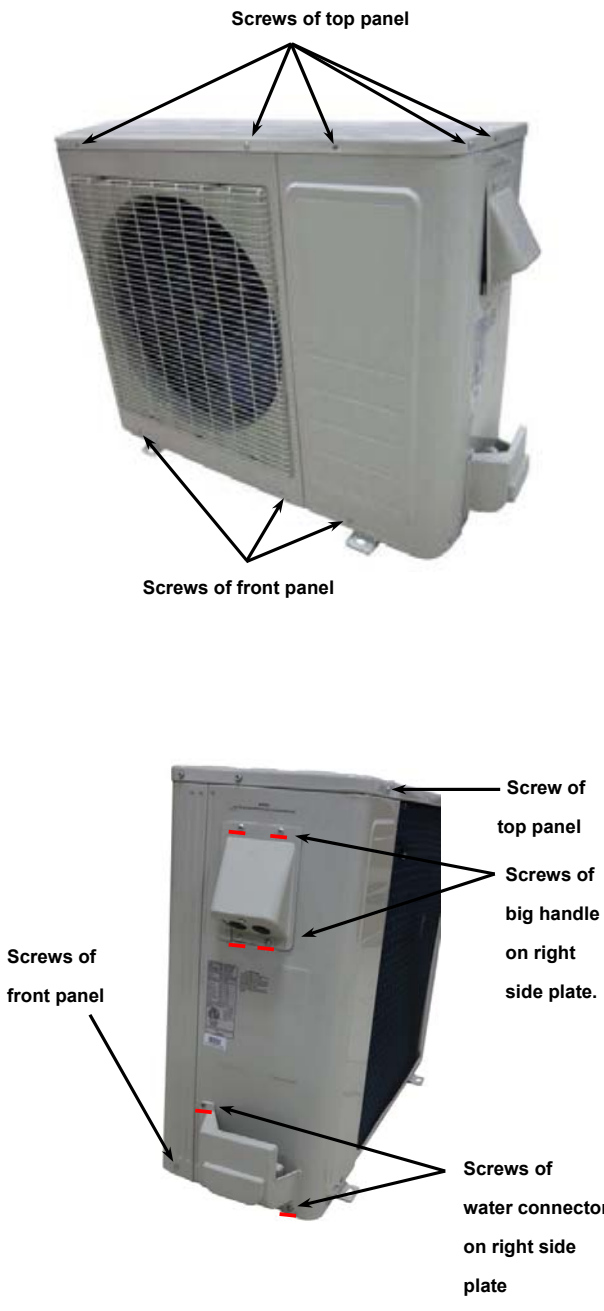
No.	Part name	Procedures	Remarks
	Panel plate	<p>How to remove the panel plate.</p> <p>1) Stop operation of the air conditioner and turn "OFF" the power breaker.</p> <p>2) Refer to the right side photos, find out the fixing screws of the panels.</p> <p>3) Remove the screws of top panel and remove the top panel.</p> <p>4) Remove the screws of the front panel, including the fixing screws of motor holder and then remove the front panel.</p>	 <p>The top photograph shows the front view of the outdoor unit. Arrows labeled 'Screws of top panel' point to four screws along the top edge. Arrows labeled 'Screws of front panel' point to four screws along the bottom edge of the front panel.</p> <p>The bottom photograph shows the back view of the unit. Arrows point to various screws: 'Screw of top panel' at the top edge, 'Screws of big handle on right side plate' on the right side, 'Screws of front panel' on the bottom edge, and 'Screws of water connector on right side plate' on the right side near the bottom.</p>

5) Remove the screws of the right side plate and remove the right side plate.

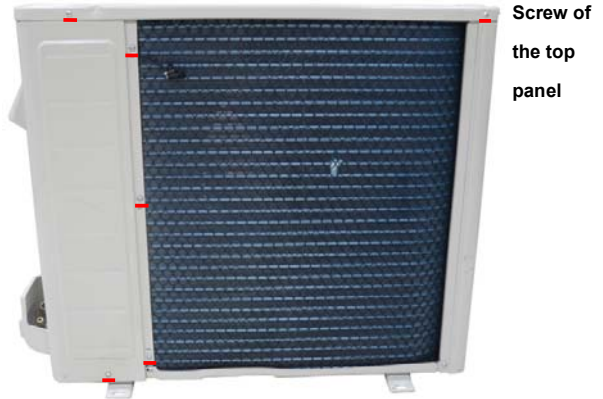

Screw of the top panel

Screws of right rear plate

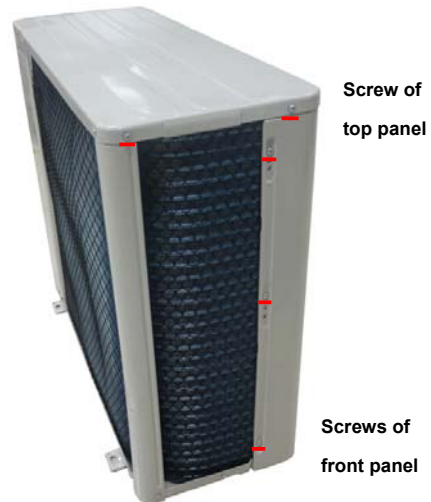

Screw of top panel

Screws of front panel



Screws of the motor holder

2 Fan ass'y

How to remove the fan ass'y.

1) After remove the panel plate following procedure 1, remove the hex nut fixing the fan and then remove the fan.

2) Remove the one fixing screw. Unfix the hooks and then open the electronic control box cover.

3) Release the fan motor connector and four way valve connector.

4) Remove the four fixing screws of the fan motor.

5) Then remove the fan motor.

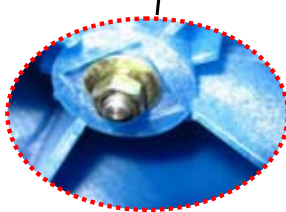
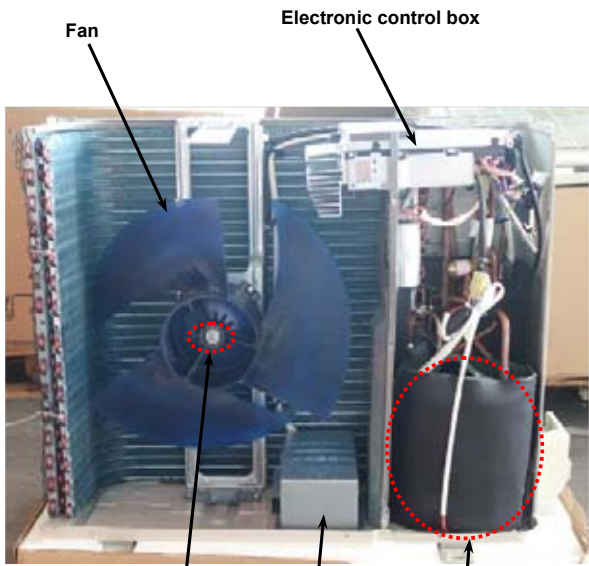

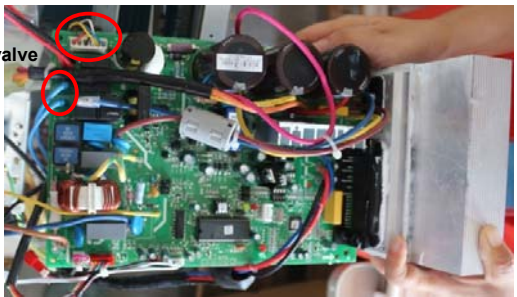
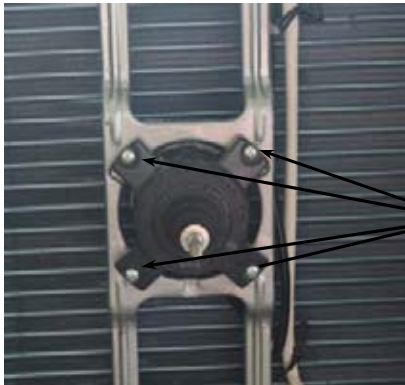
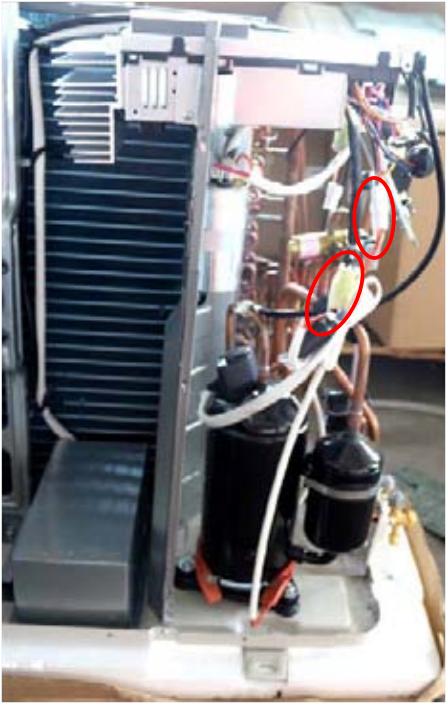
			<p>Fan motor connector</p>  <p>Four way valve connector</p>  <p>Four screws</p>
3	Electrical parts	<p>How to remove the electrical parts.</p> <p>1) After finish work of item 1 and item 2, remove the two connectors for the compressor and the compressor crankcase heater.</p> <p>2) Release the three temp. sensor connectors.</p>	

3) Remove the connector of reactor.



4) Remove the connector of electronic expansion valve.

5) Remove the grounding screw.

6) Remove the power supply wires(L1,L2,S).

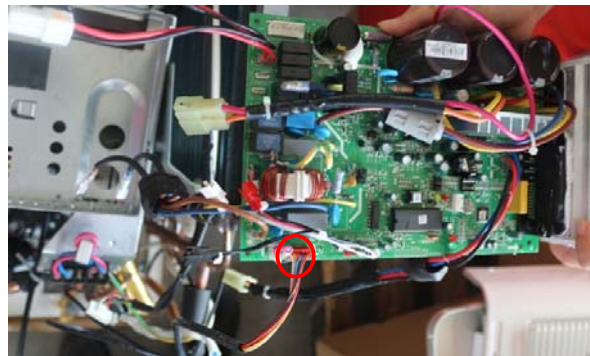
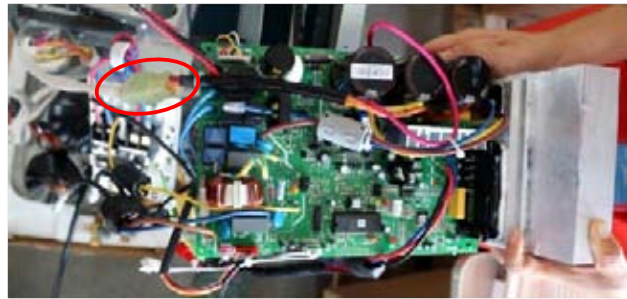
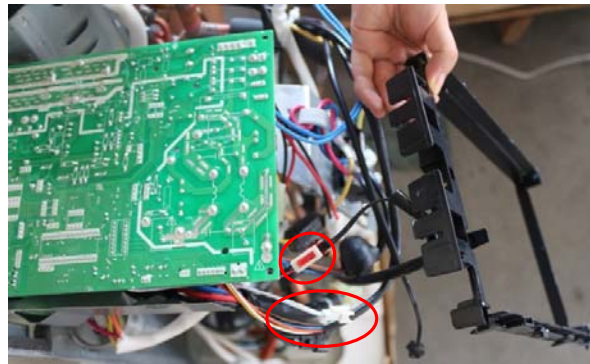
7) Then remove the electronic control box.

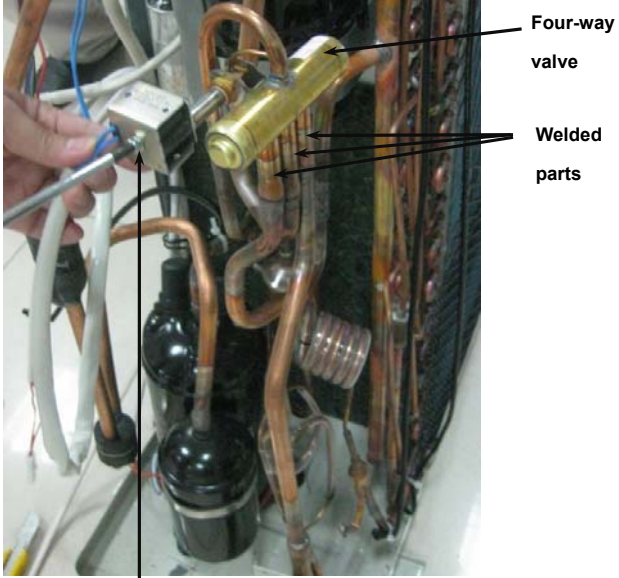

<p>4</p>	<p>Four-way valve</p>	<p>How to remove the four-way valve.</p> <ol style="list-style-type: none"> 1) Perform work of item 1,2,3. 2) Recover refrigerant from the refrigerant circuit. 3) Remove the screw of the coil and then remove the coil. 4) Detach the welded parts of four-way valve and pipe. 5) Then the four-way valve ass'y can be removed 	<p>The picture of four-way valve may be different from the one on your side.</p>  <p>Four-way valve</p> <p>Welded parts</p> <p>Coil of four-way valve, fixing by one screw.</p>
<p>5</p>	<p>Compressor</p>	<p>How to remove the compressor.</p> <ol style="list-style-type: none"> 1) After perform work of item 1,2,3. 2) Remove the discharge pipe and suction pipe with a burner. 3) Remove the hex nuts and washers fixing the compressor on bottom plate. 4) Lift the compressor from the base pan assembly. 	 <p>Discharge pipe and suction pipe</p> <p>Nuts of compressor</p>

➤ YN024GMFI22RPD

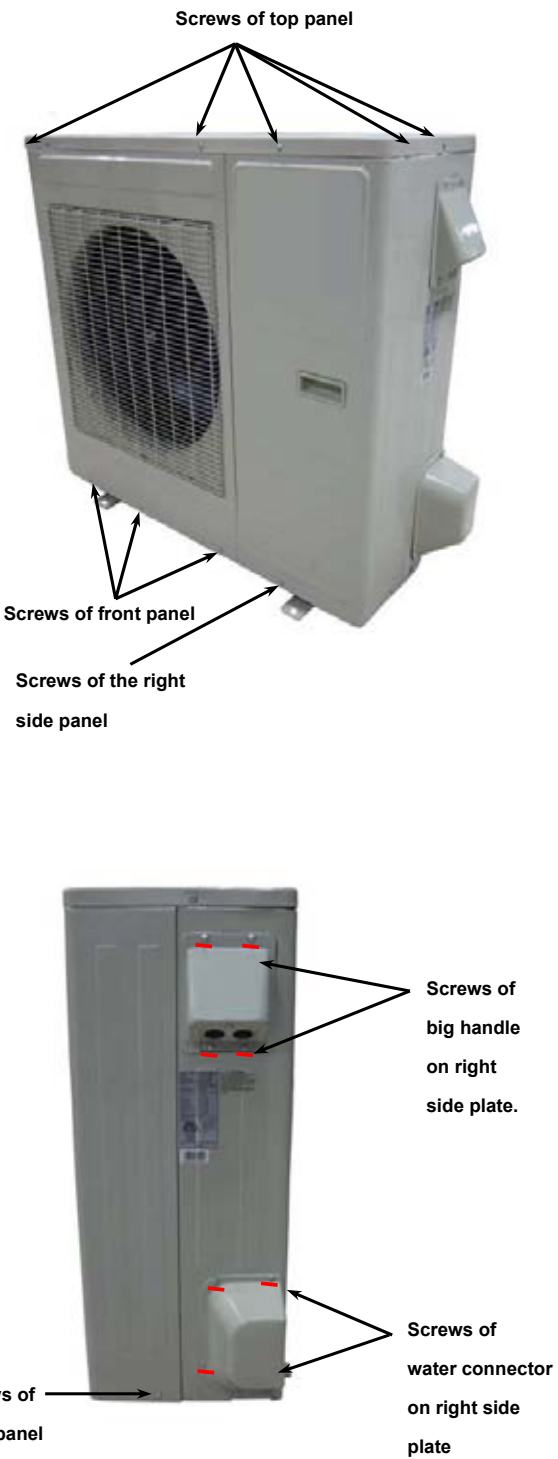
No.	Part name	Procedures	Remarks
1	Panel plate	<p>How to remove the panel plate.</p> <p>1) Stop operation of the air conditioner and turn "OFF" the power breaker.</p> <p>2) Refer to the right side photos, find out the fixing screws of the panels.</p> <p>3) Remove the screws of top panel and remove the top panel.</p> <p>4) Remove the screws of the front panel, including the fixing screws of motor holder and then remove the front panel.</p>	 <p>The top photograph shows the outdoor unit from a three-quarter perspective. Arrows point to the top panel screws, front panel screws, and right side panel screws.</p> <p>The bottom photograph shows the back of the outdoor unit. Arrows point to the screws of the front panel, the screws of the big handle on the right side plate, and the screws of the water connector on the right side plate.</p>

5) Remove the screws of the right side plate and remove the right side plate.

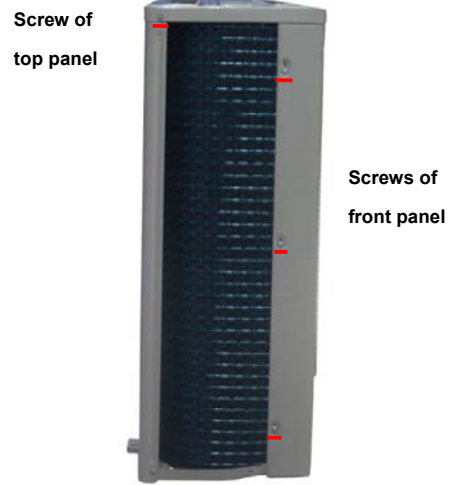



2 Fan ass'y

How to remove the fan ass'y.

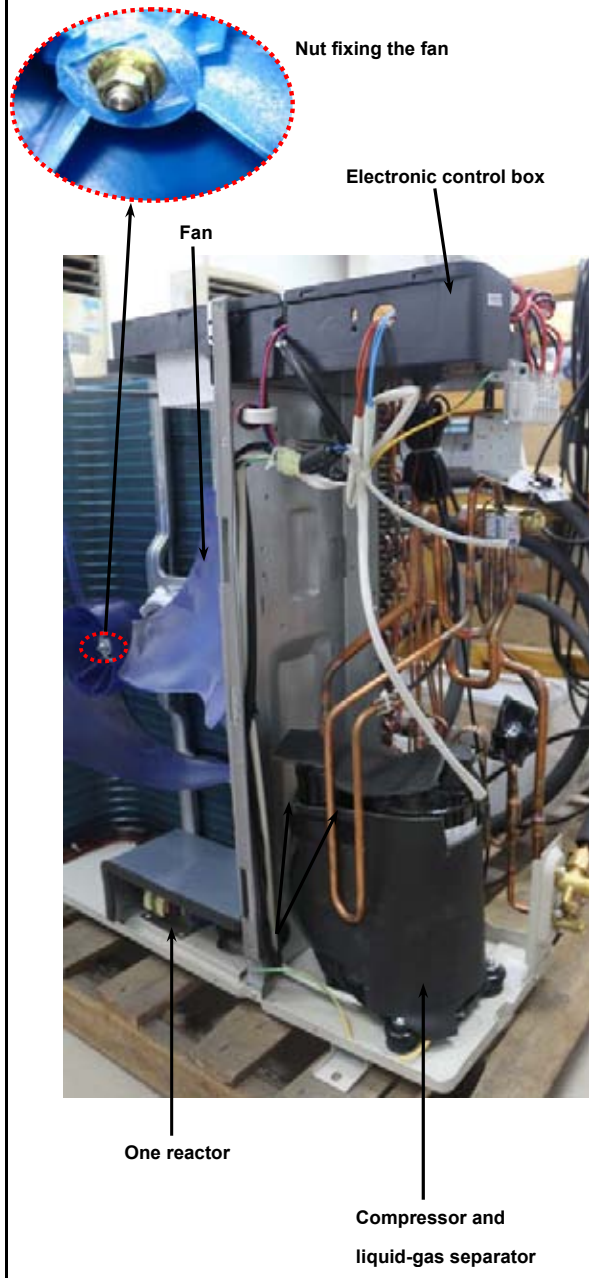
1) After remove the panel plate following procedure 1, remove the hex nut fixing the fan and then remove the fan.

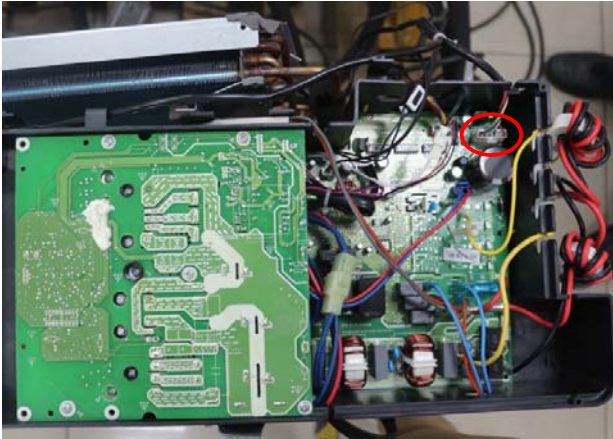

		<p>2) Remove the connector of the fan motor.</p> <p>3) Remove the four screws and the remove the fan motor.</p>	 
3	Electrical parts	<p>How to remove the electrical parts.</p> <p>1) After finish work of item 1 and item 2, remove the connector of the compressor.</p>	

2) Remove the six screws fixing the IPM board.

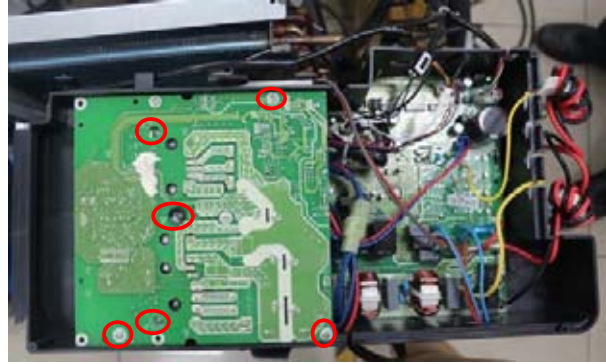

3) Release the three connectors of the temp. sensor.

4) Pull out the two blue wires connected with the four way valve.

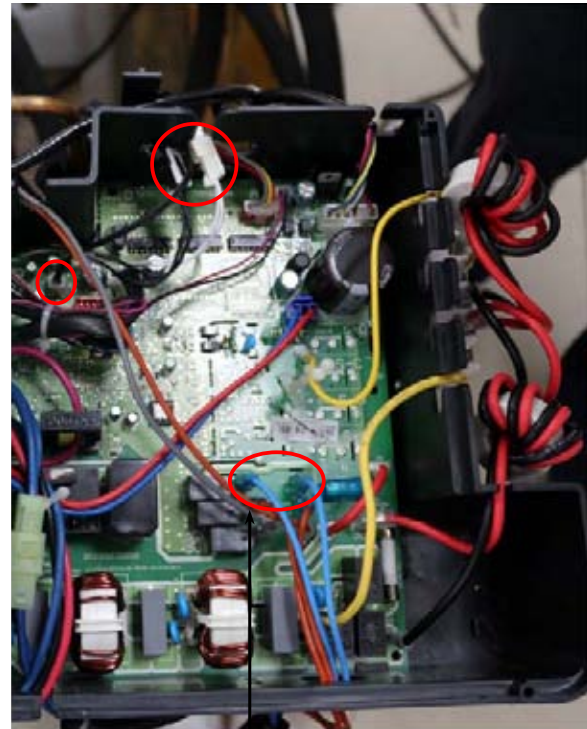

Two blue wires of four way valve

5) Pull out the four wires of electrical heater (three orange wires, one grey wire).

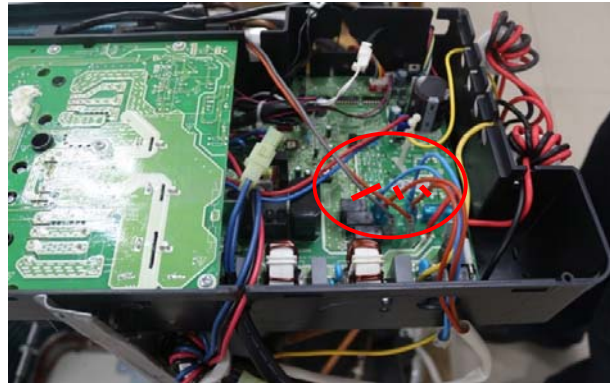

6) Pull out connectors of the compressor top temp. sensor, condenser coil temp. sensor(T3), outdoor ambient temp. sensor(T4) and discharge temp. sensor(T5).

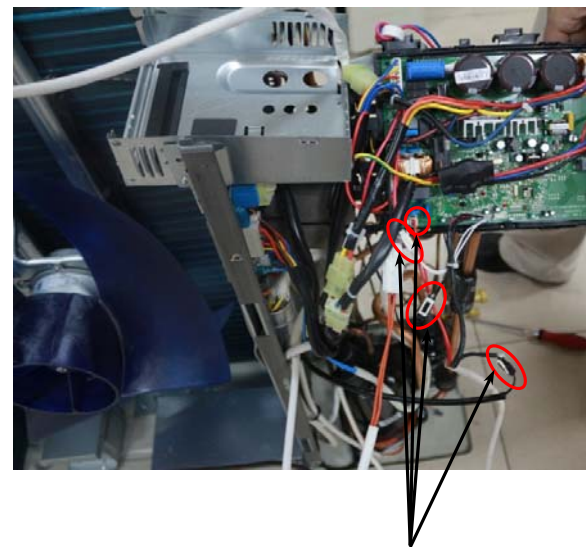

Four temp. sensor connectors

7) Remove the grounding screw.

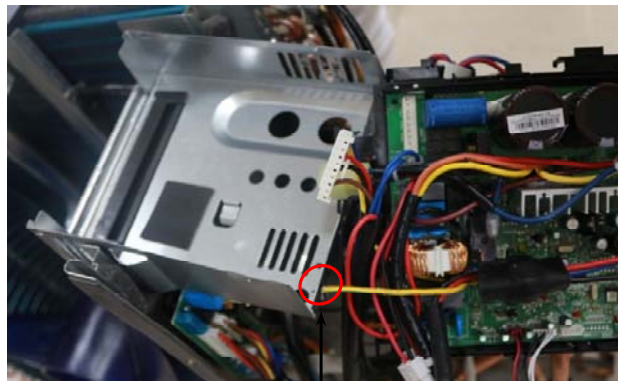

Grounding screw

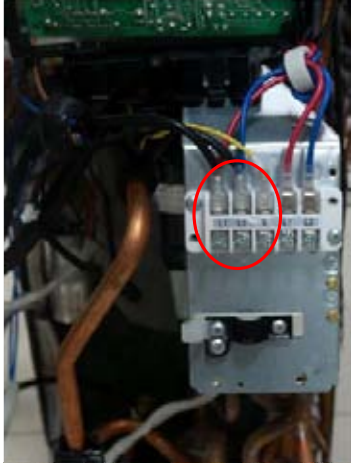
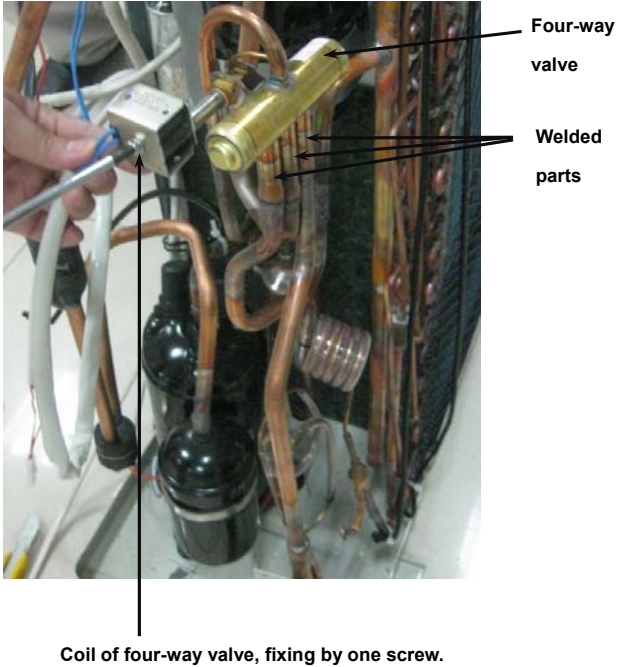
		<p>8) Remove the power supply wires(L1,L2,S). 9) Then remove the electronic control box.</p>	
<p>4</p>	<p>Four-way valve</p>	<p>How to remove the four-way valve. 1) Perform work of item 1,2,3. 2) Recover refrigerant from the refrigerant circuit. 3) Remove the screw of the coil and then remove the coil. 4) Detach the welded parts of four-way valve and pipe. 5) Then the four-way valve ass'y can be removed</p>	<p>The picture of four-way valve may be different from the one on your side.</p> 

5	Compressor	<p>How to remove the compressor.</p> <ol style="list-style-type: none">1) After perform work of item 1,2,3.2) Remove the discharge pipe and suction pipe with a burner.3) Remove the hex nuts and washers fixing the compressor on bottom plate.4) Lift the compressor from the base pan assembly.
---	------------	---

